



ICST - Congress 2007

Abstract

The 51/60DF Engine – The New Prime Mover from MAN Diesel SE

Dipl.-Ing. Oliver Bille, MAN Diesel SE, Augsburg

The use of gaseous fuels on vessels for propulsion has become more and more reality in the last years. This has been shown not only in standard gas applications (e.g. LNG Carrier propulsion) but also in other marine applications with different types of vessels (e.g. coastal ferries, Offshore vessels, patrol vessels). Further applications (e.g. cruise vessels) are already in the detailed investigation process for the possible next class of newbuildings in the future.

Several papers and presentations have been published with this subject from different parties, e.g. classification societies, state authorities, engine makers and oil and gas companies.

One reason for the increased application of gas engines and Dual-Fuel engines also on ships will be today's better availability of gaseous fuel in form of LNG (Liquefied Natural Gas) in some coastal countries of the world (e.g. Norway, Japan) because of own gas production or increased LNG imports. Other reasons will be the more and more stringent exhaust gas emission regulations in these countries for land based power generation and also for the marine shipping industry for coastal service in the last years. The use of gas engines and gas turbine in land based applications to fulfil more stringent exhaust gas emission regulations have been practiced and increased in these countries with positive operation experience for decades now. These countries are also working as frontrunners in the marine application with special governmental developments programs.

In addition the recent cost increase for liquid fuel oils in the marine shipping industry and additional operation cost for necessary exhaust gas after treatment plants on-board of the vessels have increased the interest of ship owners to investigate the use of gaseous fuels (mainly Methane CH_4) for ship propulsion.

The fuel characteristic and possibilities of storing natural gas either as LNG in liquefied stage (under atmospheric pressure, very low temperature) or in gaseous stage as CNG (Compressed Natural Gas under very high pressure) in a special insulated tank onboard of a vessel will be explained. The design requirements for using a gas engine (spark ignited) or a dual-fuel engine in an enclosed engine room will be short listed.

This presentation will be focussed on the use of a medium speed 4-stroke Dual-fuel engine in a Diesel electric propulsion system (DFDE) as multi-engine-plant which will be used today for a large number of newbuildings for LNG Carriers. In this system the same advantages can be realized like in a Diesel electric propulsion system with conventional HFO Diesel engines (redundancy, operation on high engine efficiency etc.).

For the purpose of an efficient power generation with either gaseous or liquid fuels, the MAN Diesel SE has developed the new 51/60 dual-fuel engine.

The design draws extensively on well-proven componentry from the 1200 kW/cylinder 48/60B HFO engine, which has an excellent record of high availability and has gained wide acceptance since its 2002 introduction, with more than 150 engines sold and over 330,000 total running hours achieved. Additionally the MAN Diesel SE can rely on their longtime experience with gas and dual-fuel engines for this newest development. The 51/60DF engine combines the existing strengths of the 48/60B HFO engine with state of the art dual-fuel technology.

Functional principle of dual-fuel engines:

The 51/60DF engine operates in gaseous and liquid fuel mode. In gas mode the engine operates according to the lean-burn Otto combustion process. The premixed lean gas/air mixture is ignited by the compression ignition of a small quantity of injected MDO-pilot fuel into the main combustion room. The amount of this injected pilot fuel is less than 1% of the normal liquid fuel quantity. This ensures very low NO_x emissions in the gas mode. In gaseous fuel operation, a common-rail concept is employed for pilot fuel oil injection. In the liquid fuel mode, the fuel oil is injected via the conventional main pumps known from the 48/60B HFO engine. The thermodynamic working process is the diesel combustion process. The range of usable fuel qualities in this fuel mode ranges from Marine Diesel Oil (MDO) to Heavy Fuel Oil (HFO).

Development goals:

The development targets of this Dual-Fuel engine for either marine and stationary use were a high thermal efficiency combined with a high power output in both gas and liquid fuel mode. Additionally, the engine has been designed for low NO_x emissions in the gas mode and the latest IMO NO_x limits in the liquid fuel mode.

To reach these targets the MAN Diesel SE used sophisticated and state-of-the art development tools like 3D-Computer Aided Design and 3D-Computational Fluid Dynamics to develop the gas related components. Other components, which had not been newly developed, are derived from the proven 48/60B HFO engine and therefore ensure a reliable and safe operation together with the known high availability of this type of engine.

Engine Design:

The engine is available in L-type with the 6 to 9 Cylinder configurations and in V-type the range is from 12 to 18. The high cylinder output of 1000 kW/cyl. is realized with a speed of 514 rpm. The increase in bore dimension from the 48/60B's 480mm to 510 mm in the 51/60DF is designed to enable high output at a reliable level of brake mean effective pressure (bmep).

To extend the existing 48/60B design to the 51/60DF, additional components were developed and installed on the new engine.

An essential design feature of the new 51/60DF is a control flap to control the air to fuel ratio of the cylinders. The air to fuel ratio permits a stable operation in gas mode with high efficiency and low emissions. The electronically driven gas valves feed each cylinder individually with precisely the amount of fuel gas required.

The electrical actuator controls the main injection pumps together with a phase pick-up which delivers the required signals of crank angle position in the liquid fuel mode.

For a reliable gas operation the knocking control system plays an important role. The knocking behaviour is detected for each cylinder unit individually by an acoustic sensor mounted on the cylinder head. The independent acoustic signals are fed into the main sensor unit where the knocking level is detected. The overall engine control system reacts to the knocking level and makes appropriate changes in the engine parameters. For safety reason, pressure relief valves are mounted on charge air manifold and exhaust gas manifold. The injection of the small pilot fuel quantity is performed by an electrically driven common rail pump and a solenoid activated pilot fuel oil injector.

Control System Design:

Parallel to the new engine design the class-approved and reliable MAN Diesel SE Control System SaCoS (Safety and Control System) has been extended and adopted to dual-fuel operation. The SaCoS DF system controls the air to fuel ratio via the compressor bypass flap. The systems architecture is dominated by two independent working governors. One governor controls the main injection fuel oil pumps and the individual fuel gas admission valves for each cylinder unit. The second governor controls the common-rail pilot fuel injectors. The individual knocking levels, collected from each cylinder by the knocking detection unit are processed in the SaCoS DF system. In combination with the cylinder individual control of the pilot injection and the gas admission, the SaCos DF control ensures a stable operation in gas mode with a sufficient margin to knocking and misfiring border. In addition the control system connects to the ship's overall alarm and safety systems.

To install a dual-fuel engine driven diesel-electric power generation set on a marine application, various new safety aspects and regulations by IMO, classification societies etc. have to be considered. For this purpose, the MAN Diesel SE, together with different classification societies, has developed an overall safety concept covering all relevant issues to ensure a safe and reliable operation of this new propulsion concept. In the safety concept MAN Diesel SE uses modern investigation methods like HAZID/HAZOP and FMEA.

A test engine of type 7L 51/60DF has started operation on the testbed of MAN Diesel's Augsburg works in September 2006 and the test program will proceed until end of December 2007. The testbed results are quiet optimistic: All the design parameters for engine power and performance have been reached, some parameters will be further optimized during this year and also the required operation with HFO in liquid fuel mode shows positive results for engine reliability.

During first half of this year MAN Diesel SE already wins two orders for it's new type of DF-engine: One is a retrofit solution for a stationary power plant in Spain to convert an existing 48/60B HFO engine into a DF-engine. The second order is for a newbuilding of a LNG Carrier with DFDE propulsion system from the Korean Shipyard STX Shipbuilding for a European ship owner.

Conclusions:

Natural gas (LNG, CNG) is usable as gaseous fuel in a combination with a Dual-Fuel Diesel-electric plant for the propulsion of vessels.

In addition to standard gas applications (e.g. LNG Carrier) several marine applications have been realized today and further will be investigated and realized in near future.

The use of Dual-Fuel engines will be optimal for vessels with worldwide and coastal service, e.g. in terms of redundancy (back-up fuel).

MAN Diesel SE has developed the new 51/60DF engine to offer a reliable power generation solution for both marine and stationary applications.

ICST Congress 2007, September 13th 2007 The new 51/60 DF Engine



ICST - Congress 2007

"Verein der Schiffs - Ingenieure zu Hamburg e.V."

Subject: Innovation at machinery of ship propulsion

Thursday, 13.09.2007 in Hamburg

CONTENTS

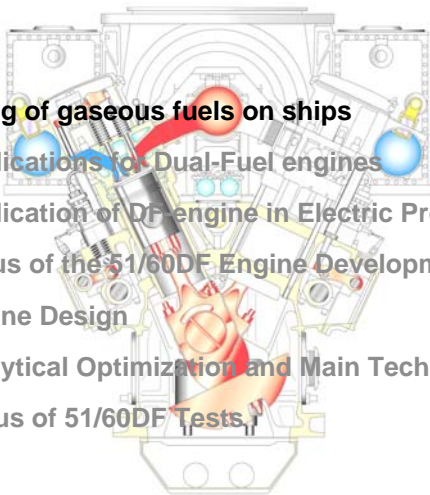

- 
1. Using of gaseous fuels on ships
 2. Applications for Dual-Fuel engines
 3. Application of DF engine in Electric Propulsion System
 4. Focus of the 51/60DF Engine Development
 5. Engine Design
 6. Analytical Optimization and Main Technical Data
 7. Status of 51/60DF Tests

Using of gaseous fuel on ships Main objectives



Today's requirements from different parties (owner, charterer, authorities) for ship propulsion of newbuildings:

- Less fuel costs
(→ consumption, because of fuel cost increase)

- Less exhaust gas emissions during voyage and harbor stay
(because of stricter regulations)

- Equivalent Safety, Reliability for other types of fuels
(compared to liquid fuels)

Using of gaseous fuel on ships Design requirements



Natural gas can be stored on vessels:

- In gaseous form (CNG), compressed under high pressure (up to 300 bar)
OR
- In liquid form (LNG), under very low temperatures and atmospheric pressure

Requirements:

- Special fuel gas containment system
- To be integrated in vessel design
- Gas and Dual-fuel engines require a special design of fuel gas supply system (fuel gas pressure, Methane number, LHV etc.)
- Special design for Engine room arrangement according to MAN Diesel Safety Concept and existing rules of classification societies

Liquefied Natural Gas (LNG) Properties and characteristics



General:

- LNG is natural gas that has been liquefied by being cooled to approximately $-160\text{ }^{\circ}\text{C}$ at atmospheric pressure
- LNG $\sim 1/600$ volume of natural gas, making it practical to transport by ship

Properties and characteristics:

- Typically 95% Methane (CH_4) with small amounts of Ethane, Propane, Butane and Nitrogen
- Colorless, odorless, non-toxic, non-carcinogenic and in liquid form is $\sim 45\%$ the density of water
- Vapors are $\sim 50\%$ density of air and will rise under normal atmospheric conditions (Propane/Butane heavier than air)
- Can be stored and transported in insulated tanks at standard atmospheric pressure

CONTENTS

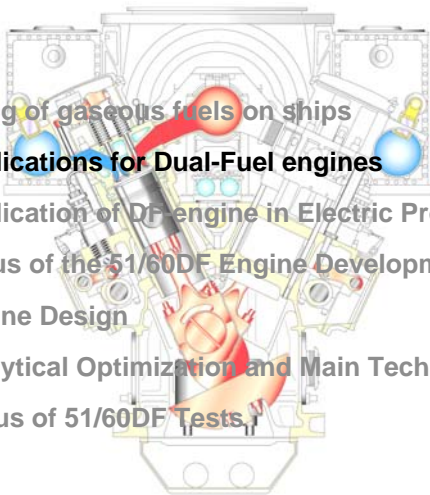

1. Using of gaseous fuels on ships
 2. Applications for Dual-Fuel engines
 3. Application of DF engine in Electric Propulsion System
 4. Focus of the 51/60DF Engine Development
 5. Engine Design
 6. Analytical Optimization and Main Technical Data
 7. Status of 51/60DF Tests
- 

Applications Marine LNG Carrier



MAN Diesel

ICST Congress 2007 - The New 51/60DF Engine

© MAN Diesel SE

Sept. 2007

<8>

Applications Marine Ferries (Passenger, Car, RoRo)



MAN Diesel

ICST Congress 2007 - The New 51/60DF Engine

© MAN Diesel SE

Sept. 2007

<9>

Applications Marine Cruise Vessels



MAN Diesel

ICST Congress 2007 - The New 51/60DF Engine

© MAN Diesel SE

Sept. 2007

<10>

Applications Marine Patrol Vessels



MAN Diesel

ICST Congress 2007 - The New 51/60DF Engine

© MAN Diesel SE

Sept. 2007

<11>

Applications Offshore FPSO, Supply Vessels



MAN Diesel

ICST Congress 2007 - The New 51/60DF Engine

© MAN Diesel SE

Sept. 2007

<12>

Application Stationary Power Plant with DF-engines



MAN Diesel

ICST Congress 2007 - The New 51/60DF Engine

© MAN Diesel SE

Sept. 2007

<13>

CONTENTS

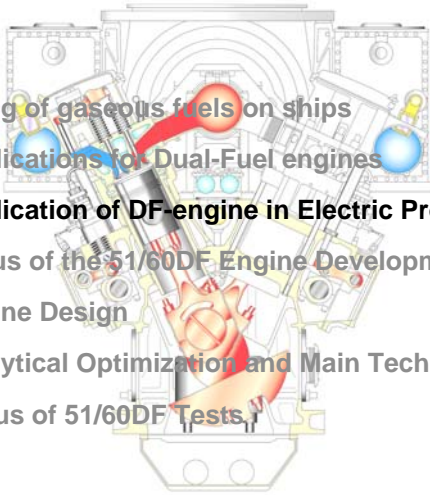

- 
1. Using of gaseous fuels on ships
 2. Applications for Dual-Fuel engines
 3. Application of DF engine in Electric Propulsion System
 4. Focus of the 51/60DF Engine Development
 5. Engine Design
 6. Analytical Optimization and Main Technical Data
 7. Status of 51/60DF Tests

Basics of 51/60 DF engine Operation Modes (1)



Diesel mode

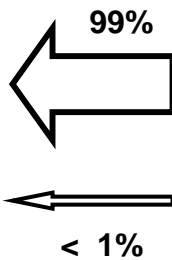
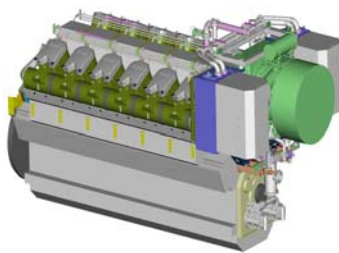

Main fuel nozzle

MDO (DMA, DMB)
HFO

Pilot fuel nozzle

MDO (DMA, DMB)

Basics of 51/60 DF engine Operation Modes (2)



Gas mode

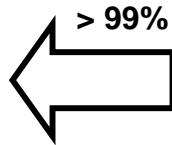
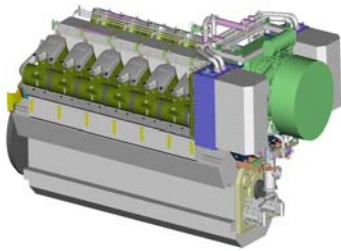

Gas admission valve

Natural gas
(vaporized LNG)

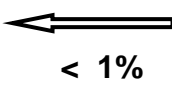

Pilot fuel nozzle

MDO (DMA, DMB)

Dual-Fuel Electric Propulsion e.g. LNG Carrier

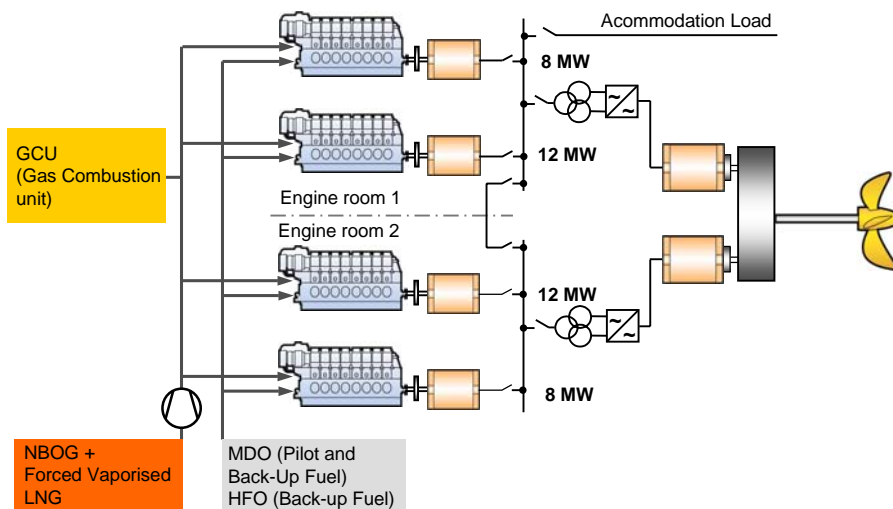

Dual-Fuel Electric Propulsion e.g. LNG Carrier (Arrangement)



MAN Diesel

ICST Congress 2007 - The New 51/60DF Engine

© MAN Diesel SE

Sept. 2007

<18>

CONTENTS



1. Using of gaseous fuels on ships
2. Applications for Dual-Fuel engines
3. Application of DF engine in Electric Propulsion System
4. Focus of the 51/60DF Engine Development
5. Engine Design
6. Analytical Optimization and Main Technical Data
7. Status of 51/60DF Tests

MAN Diesel

ICST Congress 2007 - The New 51/60DF Engine

© MAN Diesel SE

Sept. 2007

<19>

MAN Diesel References 32/40DF Engine (Status 10-2006)



- 16 Engines in service
- 184 cylinders
- 160.000 accumulated running hours
- Applications:
 - Stationary power plant
 - Cogeneration plant
 - Peaking power plant

Market Requirements for the New 51/60DF Engine for marine use



- Ship application
- Design to consider the requirements from marine classification societies (safety concept, FMEA etc.)
- Total fuel flexibility: Vaporized LNG, MDO (DMA, DMB), HFO
- High availability in liquid fuel and gas mode
- Safe operation in gas mode with an acceptable margin to the knocking and misfiring limit
- High power output with fuel gas of low heat value
- High efficiency in liquid fuel and gas mode

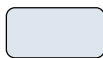

... aspect to be briefly highlighted in the following slides

MAN Diesel Safety Concept



Following main topics are considered in the safety concept for installation of DF engines on ships:

- Special design features / recommendations because of gas fueled engines in enclosed engine rooms
- Explosion protection in general (declaration of EEx-zones etc.)
- Methods for active and passive explosion protection (Ventilation, special design for explosion proof or explosion venting etc.)
- Appropriate design of mechanical and electrical parts and their required location

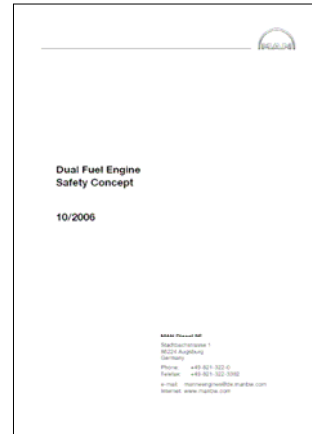

Market Requirements for the New 51/60DF Engine for marine use



- Ship application
- Design to consider the requirements from marine classification societies (safety concept, FMEA etc.)
- Total fuel flexibility: Vaporized LNG, MDO (DMA, DMB), HFO
- High availability in liquid fuel and gas mode
- Save operation in gas mode with an acceptable margin to the knocking and misfiring limit
- High power output with fuel gas of low heat value
- High efficiency in liquid fuel and gas mode

... these aspects to be briefly highlighted in the following slides

Operation Window in Gas Mode

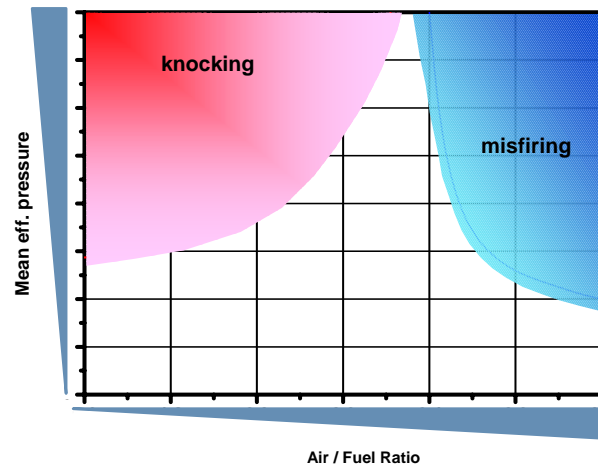

MAN Diesel

ICST Congress 2007 - The New 51/60DF Engine

© MAN Diesel SE

Sept. 2007

<25>

Gas Engine Knocking Main Parameters of Influence



- Air / Fuel ratio
- Engine load
- Timing of ignition / Pilot-fuel injection
- Charge air temperature
- Methane number
- Design of the combustion chamber

MAN Diesel

ICST Congress 2007 - The New 51/60DF Engine

© MAN Diesel SE

Sept. 2007

<26>

CONTENTS



1. Using of gaseous fuels on ships
2. Applications for Dual-Fuel engines
3. Application of DF engine in Electric Propulsion System
4. Focus of the 51/60DF Engine Development
5. **Engine Design**
6. Analytical Optimization and Main Technical Data
7. Status of 51/60DF Tests

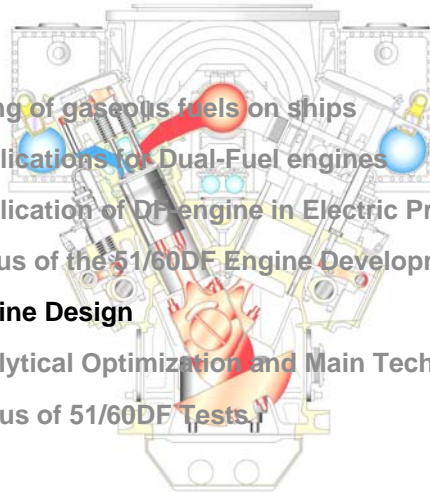

From 48/60B Parent Engine to 51/60DF - Additional Components -

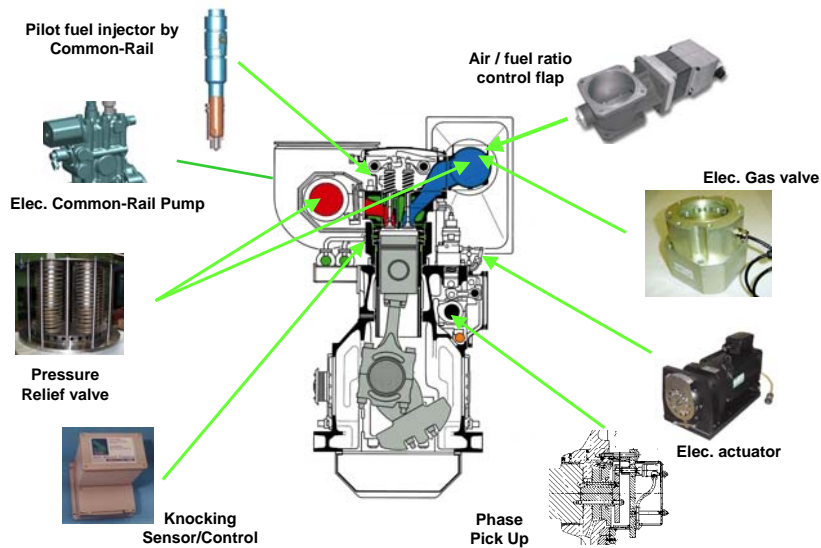

From 48/60B Parent Engine to 51/60DF - Newly Developed Mechanical Parts -



- Cylinder head with bore for pilot fuel injector and optimised inlet ports
- DF piston with a 510 mm diameter
- Liner with 510 mm bore to fit into the existing 48/60B crank case
- CR Pilot-fuel injector
- Fuel gas and CR double wall piping
- Rocker arm casing with integrated charge air manifold and gas valve connection
- Charge air manifold pressure relief valve arrangement
- Exhaust gas manifold pressure relief valve arrangement

51/60 DF, L-Engine

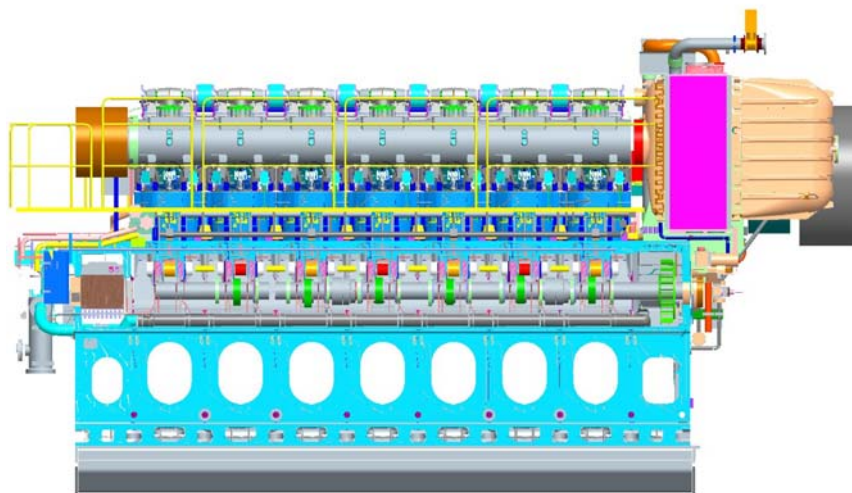

51/60 DF Cross Section

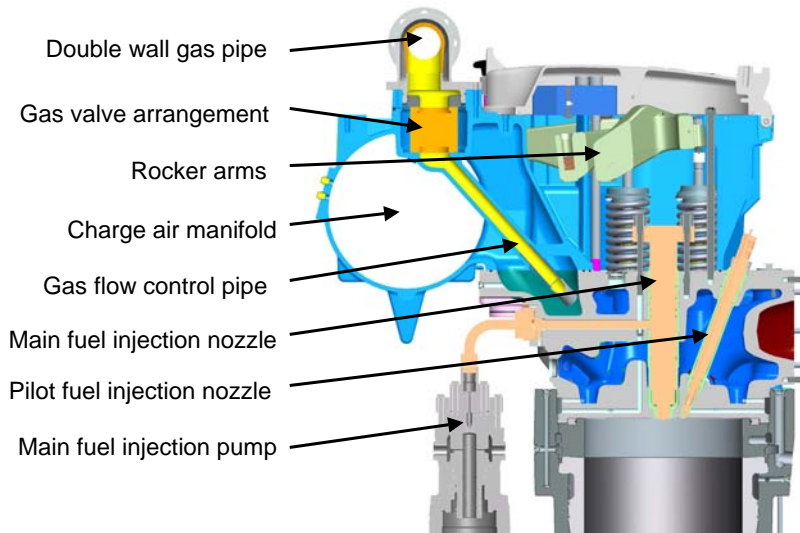

MAN Diesel

ICST Congress 2007 - The New 51/60DF Engine

© MAN Diesel SE

Sept. 2007

<31>

51/60 DF Engine Control SaCoS DF

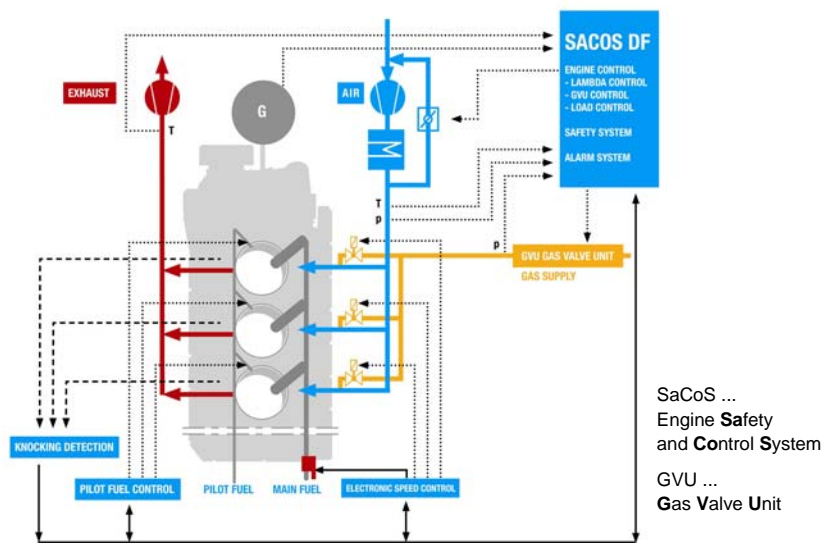

MAN Diesel

ICST Congress 2007 - The New 51/60DF Engine

© MAN Diesel SE

Sept. 2007

<32>

Test engine in Augsburg 7L 51/60DF



MAN Diesel

ICST Congress 2007 - The New 51/60DF Engine

© MAN Diesel SE

Sept. 2007

<33>

CONTENTS



1. Using of gaseous fuels on ships
2. Applications for Dual-Fuel engines
3. Application of DF engine in Electric Propulsion System
4. Focus of the 51/60DF Engine Development
5. Engine Design
6. Analytical Optimization and Main Technical Data
7. Status of 51/60DF Tests

MAN Diesel

ICST Congress 2007 - The New 51/60DF Engine

© MAN Diesel SE

Sept. 2007

<34>

Engine Development Tools



- Thermodynamic calculations:
to determine the power output , air fuel ratio,
valve lift timing and operation values
- 1D-Real Cycle Calculation (GT Power)
- 3D-Computational Fluid Dynamics (CFD) with combustion
calculation to reduce the development cost by focusing on
concepts with the biggest potential
- 3D Computer Aided Design (CAD)
- Finite Element Simulation (FEM) of linear deformation behaviour
and stress distribution to secure long lifetime of engine parts
- FMEA (cause and effect analysis) for safety issues

Gas Injection Analysis (5) Distribution of Air / Fuel Ratio

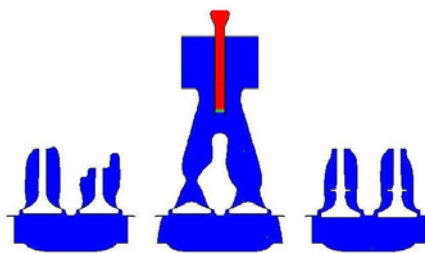
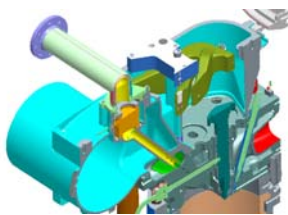

For Orientation:

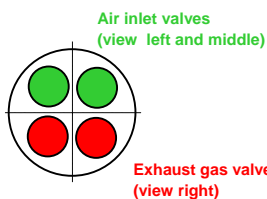

320 GKW

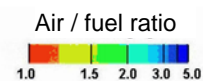

51/60 DF Main Technical Data



Number of Cylinders	L:	6, 7, 8, 9	
	V:	12, 14, 16, 18	
Speed	rpm	500	514
Cylinder Output	kW/cyl.	975	1000
Bore / Stroke	mm	510 / 600	
Power Range (at 514 rpm)	kW	6.000 – 18.000	

51/60 DF Comparison of NOx Emissions

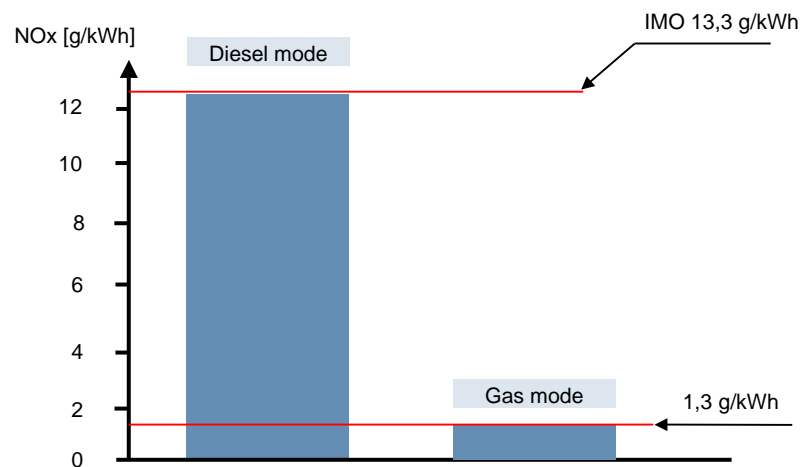

CONTENTS

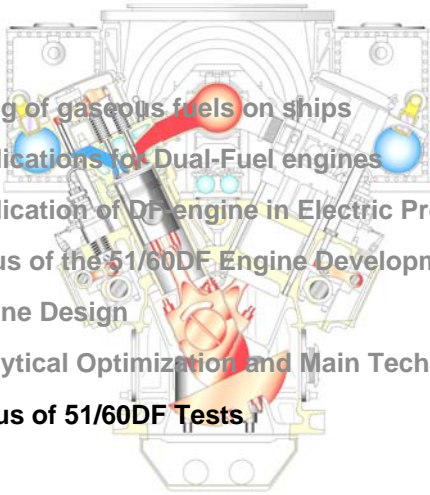

- 
1. Using of gaseous fuels on ships
 2. Applications for Dual-Fuel engines
 3. Application of DF engine in Electric Propulsion System
 4. Focus of the 51/60DF Engine Development
 5. Engine Design
 6. Analytical Optimization and Main Technical Data
 7. **Status of 51/60DF Tests**

Status 51/60DF Tests, Mid 08 / 2007



First engine start	15.09.06
First gas operation	11.10.06
First 100% MCR gas operation	19.10.06
Normal + fast switch over @ 100% MCR	05.12.06
Short operation HFO Tests started	08.01.07

Operating hours total:	949 h
operating hours MDO:	400 h
operating hours HFO:	69 h
operating hours Gas:	480 h

First inspection of components:

- Piston and piston rings:
running behaviour without remarks
- Cylinder liners:
running surface without remarks

51/60DF Time Table

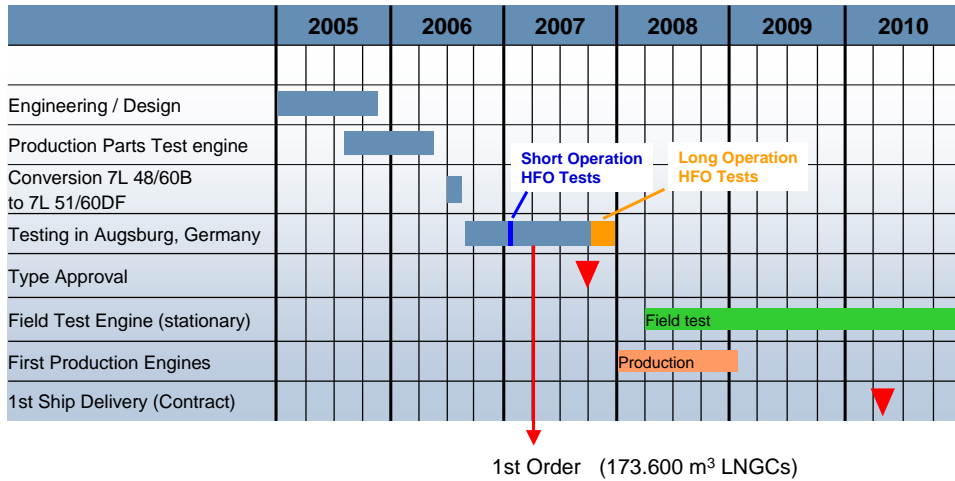

MAN Diesel

ICST Congress 2007 - The New 51/60DF Engine

© MAN Diesel SE

Sept. 2007

<41>

51/60DF engine First Reference



South Korea

- STX Shipbuilding Co. Ltd. 173,600 m³ LNGC with DFDE
- Engine configuration: 5x 8L 51,60DF, 40 MW total installed power
- Delivery of engines: Early 2009
- Delivery of first vessel: Mid 2010



MAN Diesel

ICST Congress 2007 - The New 51/60DF Engine

© MAN Diesel SE

Sept. 2007

<42>

Conclusions



- Natural gas (LNG, CNG) is usable as gaseous fuel for the propulsion of vessels.
- In addition to standard gas applications (e.g. LNGC) several marine applications have been realized today and further will be investigated and realized in near future.
- The use of Dual-Fuel engines will be optimal for vessels with worldwide and coastal service (e.g. in terms of redundancy).
- MAN Diesel has developed the new 51/60DF engine to serve this new market efficiently.

Thank you for your attention!



**The New 51/60DF Engine -
Clean DF-Power for the Future**

