

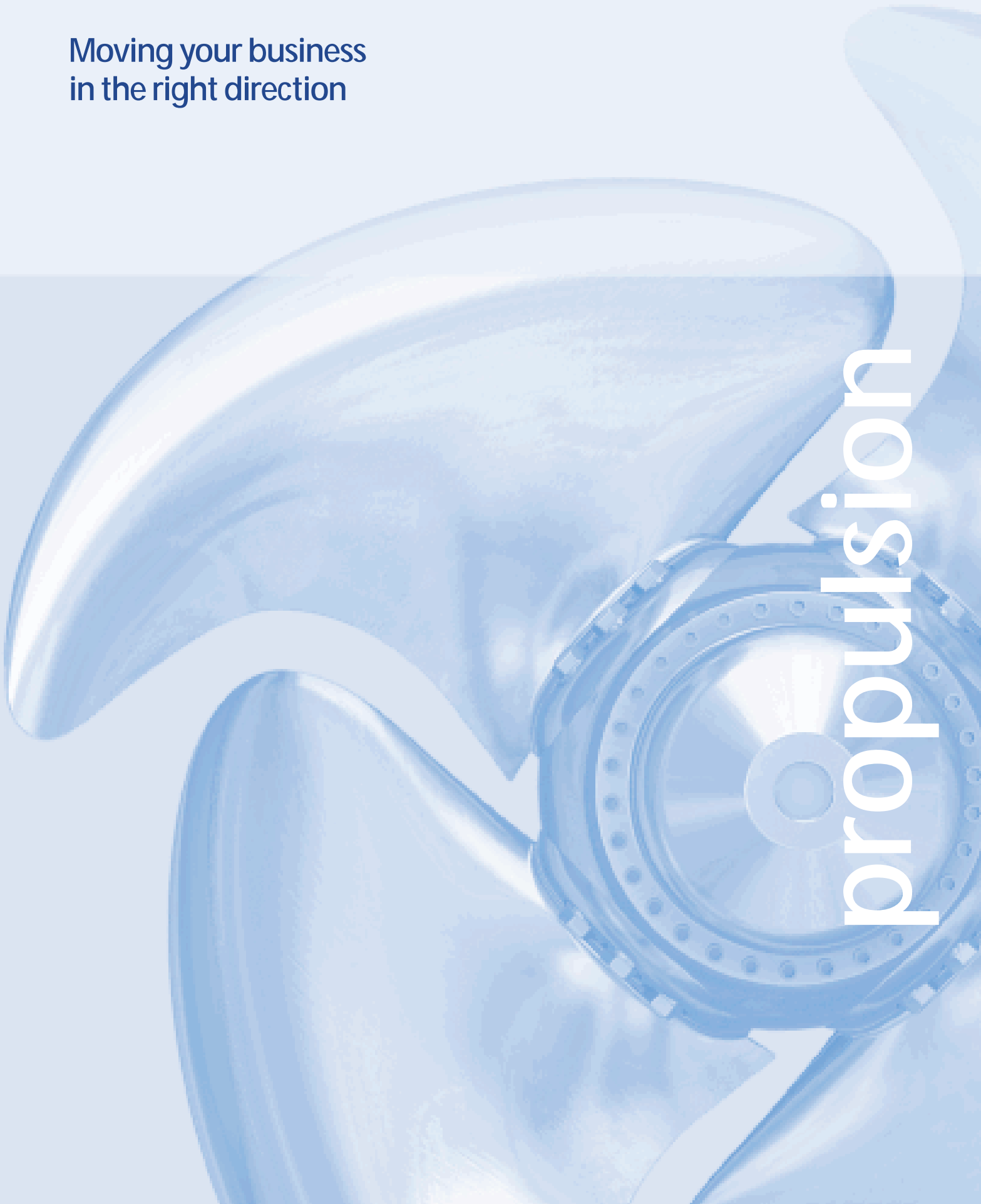

Rolls-Royce

Moving your business
in the right direction

propulsion



The force in marine propulsion

Rolls-Royce is the leading developer and supplier of propulsion equipment. A supplier who has the capability to meet your demands regarding performance and cost-effectiveness.

Ongoing research and development is the key to the success of Rolls-Royce, with a total investment in the overall product range exceeding £5 billion in the last decade. Combined with a technology and skills base accumulated over 100 years, Rolls-Royce today has the broadest range of propulsion products, services and expertise in the world.

The Rolls-Royce commitment to customer satisfaction is your guarantee of the highest levels of quality, expertise and performance. And with a truly international presence Rolls-Royce provides service and maintenance worldwide.

World famous propulsion product names by Rolls-Royce:

Kamewa™

Kamewa Ulstein™

Ulstein Aquamaster™

Bird-Johnson™ *

Fixed pitch and controllable pitch propellers in the Bird-Johnson range are designed and manufactured to US Navy MIL standards. New Generation Workwheels are supplied for the workboat market. Specialist literature available.

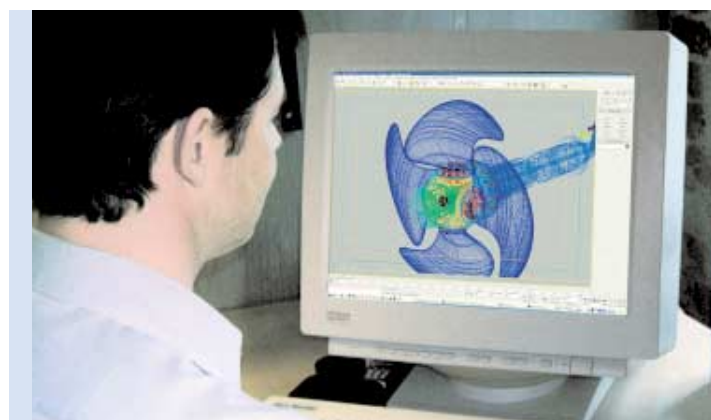

State-of-the-art technology combined with the latest hydrodynamic design codes are routinely used in the optimisation of propulsion equipment.

Content:

Propellers/reduction gears	page 2 - 9
Azimuthing thrusters	page 10 -16
Tunnel thrusters	page 17
Electrical Pod	page 18 - 19
Waterjets	page 20 - 22
Customer support	page 23 - 25

At the leading edge of propulsion technology

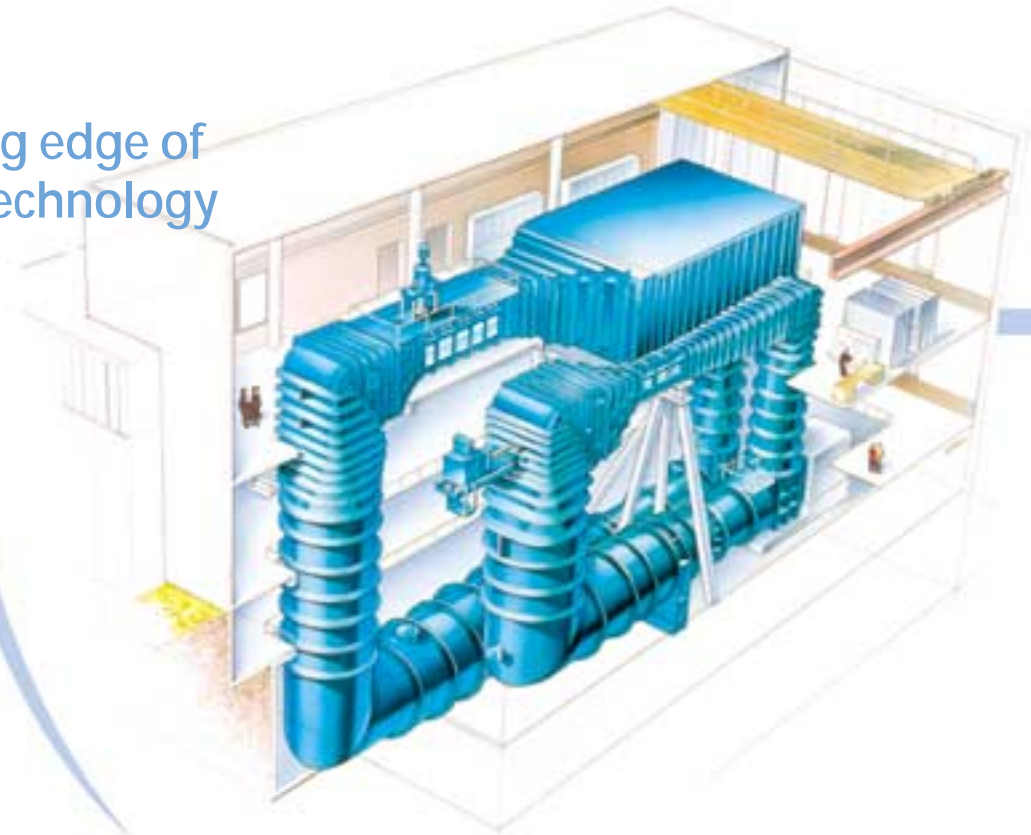

Propellers/
reduction gears

Unlike other propulsor suppliers, Rolls-Royce has its own marine propulsion laboratory in Kristinehamn, Sweden, equipped with two cavitation tunnels. A conventional closed recirculating cavitation tunnel is used for testing propellers in "open water" (i.e. not influenced by the hull) and behind the hull condition. This tunnel offers maximum flexibility for

various propeller/ship afterbody tests. One of the few free-surface type tunnels in existence, the second tunnel is used for testing high speed propellers operating in partially or fully submerged conditions, in parallel or oblique flow. Transverse and vertical forces can be measured in addition to thrust and torque, using a six-component dynamometer.

In the quest for optimum propulsion efficiency with minimum noise and vibration, Rolls-Royce engineers employ advanced theories and calculation methods. Since the laboratory first opened in 1942, about 1.200 models of sub-, semi-, and supercavitating propellers have been tested.



All propulsion products are delivered with remote control systems. The electronic control systems are undergoing continuous improvements to meet all technical and ergonomical demands.

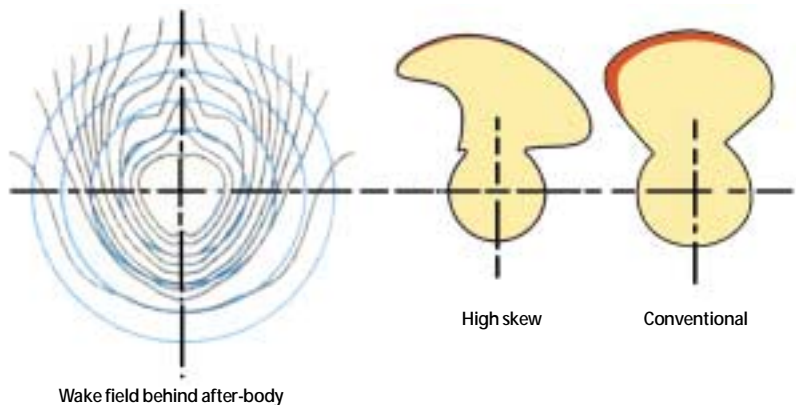

By skewing the blades, noise and vibrations can be reduced to a minimum.

Kamewa Ulstein™ controllable pitch propellers, XF5 D

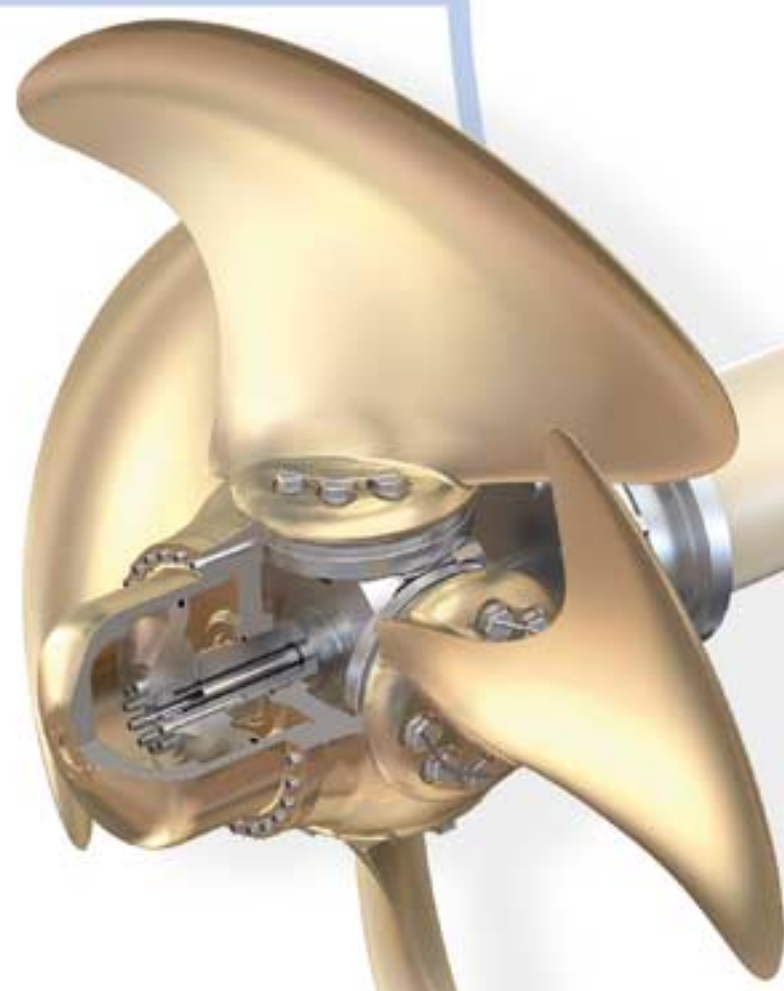

The XF5 D system is recognised as the most efficient of its type on the market today. The hub/propeller ratio has been optimised for maximum efficiency and the blade bearing arrangement modified to avoid peak pressures. This has resulted in improved stress distribution. Combined with increased pitch, this ensures greater strength and maximum propeller efficiency. The system can be supplied with four or five blades of highly skewed or

moderate skew type, conventional or nozzle design.

There are two types of Kamewa Ulstein CPP systems – type F and type M.

Type F: The oil distribution box is mounted on the forward end of the reduction gearbox. Additional intermediate shafts can be arranged between the propeller shaft and the gearbox. Type F requires the mini-

mum overall installation space, and is therefore the most favourable solution.

Type M: A separate shaft carries the oil distribution box, and additional intermediate shafts can be arranged between the propeller shaft and the OD box shaft.

The XF5 D is available in NiAl-bronze or stainless steel and is optimised for all types of installation, from no ice to highest ice class, throughout the speed range.

Underwater replacement of blades as well as feathering design are optional features.

The propeller is delivered with a low noise hydraulic power pack and remote control system.

CP propellers manufactured to meet US Navy standards including Grade A shock MIL-S-901D are available from our Bird-Johnson range.

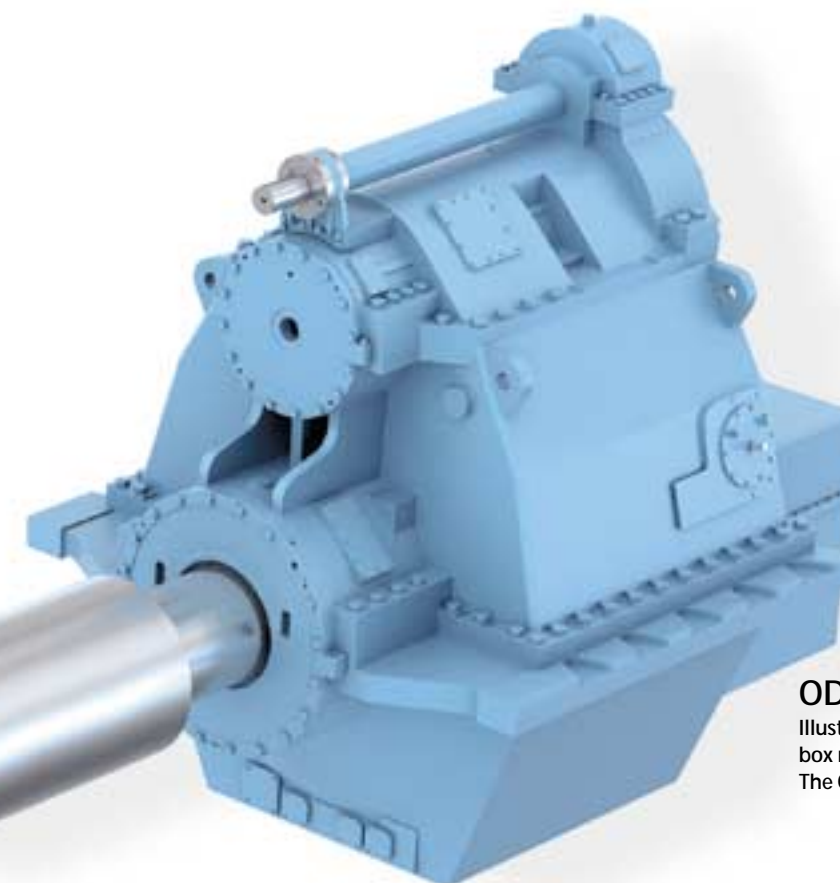

OD box in front of gearbox

Illustration showing type F system with oil distribution box mounted on the forward end of the reduction gearbox. The OD box incorporates the pitch feedback system.

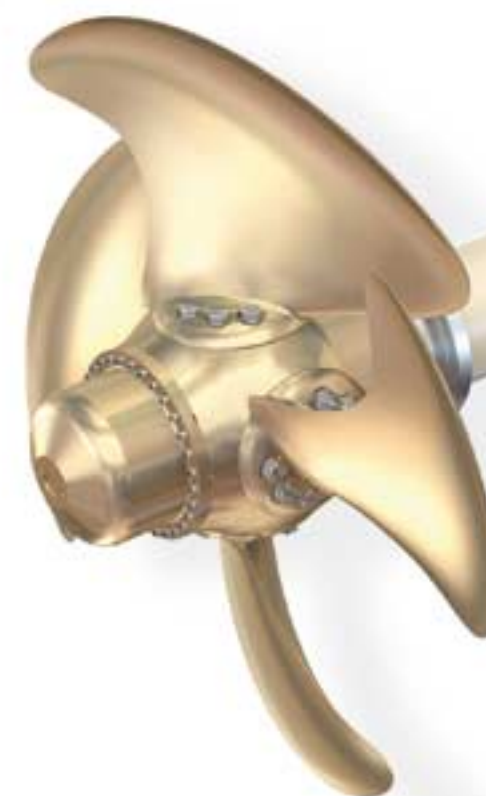

OD-box in shaft line

Illustration showing type M system with oil distribution box in the shaft line.

Typical applications:

Suitable for larger vessels such as:

- fast ferries
- cruise ships
- container ships
- cargo vessels
- tankers
- naval vessels
- offshore vessels

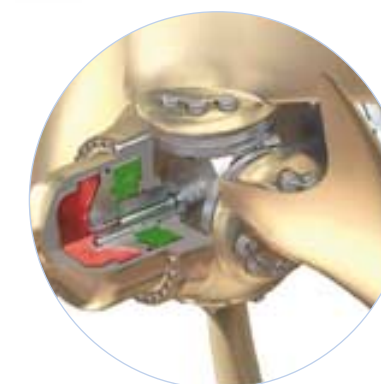

The CP function is controlled by hydraulics.

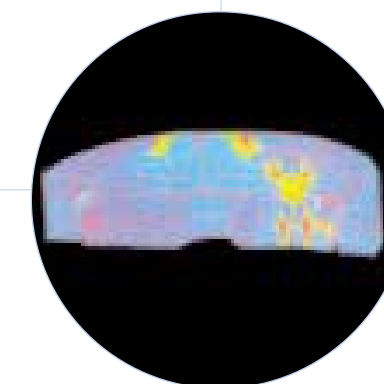

Diagram showing stress concentrations in blade attachment area.

Kamewa Ulstein™ controllable pitch propellers XF5 E, XF5 T, and integrated reduction gearboxes

The XF5 E and XF5 T controllable pitch propeller series are available in the lower power range. The system has a simple and reliable construction, including the mechanical components, hydraulics and controls. Standard and fewer components secure less maintenance; fewer and less expensive spare parts and shorter delivery times.

A tight size range guarantees optimum hub size for every application. Structurally optimised hubs mean the lowest possible stresses on the smallest possible hubs, and the highest efficiency. The system is available with hydraulically and mechanically operated pitch function.

Typical applications:

- Suitable for:
- offshore supply vessels
 - fishing vessels
 - ferries
 - tugs
 - cargo vessels/tankers
 - naval support vessels

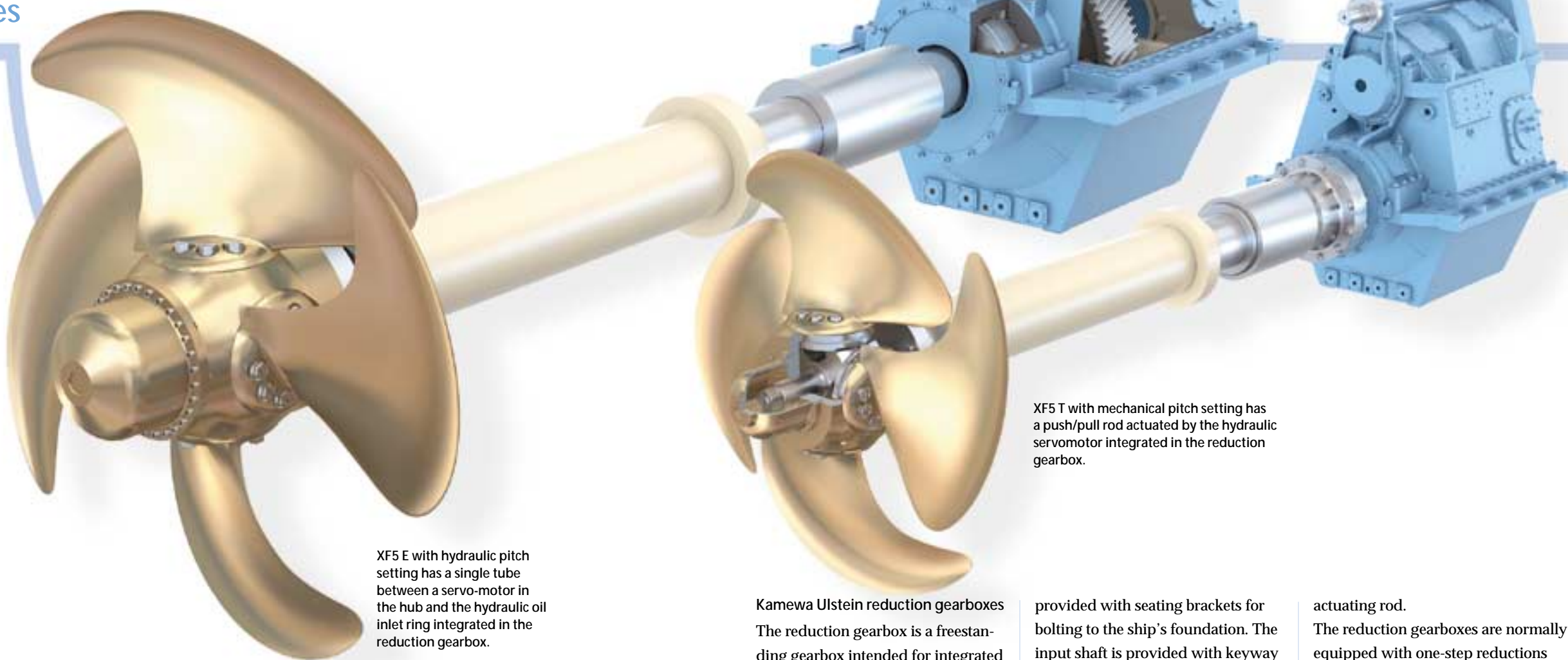

XF5 E with hydraulic pitch setting has a single tube between a servo-motor in the hub and the hydraulic oil inlet ring integrated in the reduction gearbox.

XF5 T with mechanical pitch setting has a push/pull rod actuated by the hydraulic servomotor integrated in the reduction gearbox.

Kamewa Ulstein reduction gearboxes
The reduction gearbox is a freestanding gearbox intended for integrated propulsion systems. It is designed as a combined speed reduction unit with common hydraulic system for gear and propeller. The gear has a built-in hydraulic operated clutch and is

provided with seating brackets for bolting to the ship's foundation. The input shaft is provided with keyway for mounting of the flexible coupling, and the output shaft with a cylindrical shaft or flange. The hollow bored propeller shaft carries the single oil tube or the

actuating rod.

The reduction gearboxes are normally equipped with one-step reductions from 1.5:1 to 5.95:1 (6.25:1). Some applications can be delivered with two-step reduction with max. ratio up to 12:1.



The thrust bearing is of the tilting pad type, absorbing the propeller thrust in both ahead and astern direction.

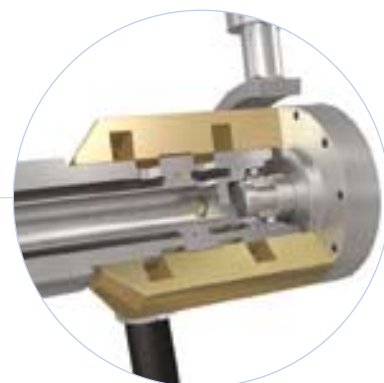

The oil distribution valve is of simple and reliable design. It floats on the oil distribution shaft.

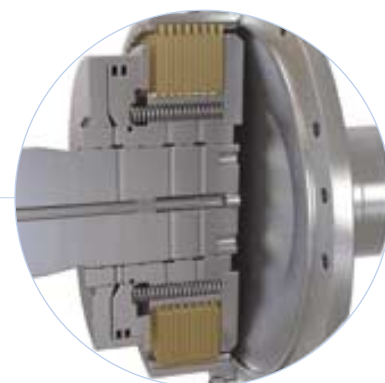

The gearbox is equipped with a mechanical driven servo oil pump, ensuring continuous oil supply also when the main clutch is disengaged.

Technical data	AGSC/AGHC	AGSC-KP/AGHC-KP
Max. Torque in (Nm)	23 000-200 000	23 000-200 000
Max. Torque out (Nm)	90 000-800 000	90 000-800 000
Reduction ratio, min./max. one-step	1.5:1-5.95:1 (6.25:1)	1.5:1-5.95:1 (6.25:1)
Reduction ratio, max. two-steps	12:1	12:1
Weight (dry), kg	3 000-25 000	3 300-23 500
Gearbox PTO transmitted power KP		800-3300 kW (1200-1800 RPM)
Max. step up ratio (one step)		1:3.5
Min. step up ratio (one step)		1:1

All data subject to change without prior notice.

Kamewa™ /Bird-Johnson™ fixed pitch propellers

Rolls-Royce has many years of experience in the design of fixed pitch propellers. In the US we have our own foundry capable of producing fixed pitch propellers up to 10m diameter in a variety of materials, to the exacting tolerances required for modern naval platforms. The characteristics of our Bird-Johnson and Kamewa FP propellers provide good fuel economy, low vibration/noise levels and no harmful cavitation. They are usually individually designed for the specific vessel to deliver the optimum in propeller efficiency.

The Kamewa-SKF propeller sleeve
This propeller sleeve is a unique concept that simplifies propeller removal and mounting, provides full interchangeability between operating propeller and spare propeller, and reduces the need for a spare propeller shaft. It offers considerable cost savings in terms of downtime, maintenance and repairs. The Kamewa-SKF propeller sleeve also generates major savings by speeding up the installation process, eliminating match marking or gauges. The Kamewa FPP is designed with either a taper shaft or SKF sleeve.

Rolls-Royce offers a complete FPP package

- Individual design
- Monoblock propellers of moderate or high-skew designs for both open and nozzle applications
- Shafting with stern tube, bearings, sealings, nozzle, etc.

The cylindrical bore ensures rapid interchange of operating propeller and spare propeller.

Typical applications:

Suitable for:

- tankers
- cargo vessels
- cruise ships
- ferries
- arctic vessels
- various types of naval vessels

- The Kamewa-SKF Propeller Sleeve
- Shaft calculations, such as whirling and alignment
- Performance guarantees

New Generation Workwheels®

Part of our Bird-Johnson product portfolio – New Generation Workwheels® – are available in five standard propeller designs specifically suited for workboats and manufactured in manganese bronze, NiAl-bronze and stainless steel.

Designed to outperform conventional three and four bladed designs, New Generation Workwheels apply state-of-the-art technology routinely used in the design of large commercial and naval propellers. The improved performance is a result of the application of latest hydrodynamic design codes, which are applied in both design and off design operating conditions.

Key features:

- Five blades
- Optimised variable pitch distribution
- Non-linear blade skew of 18 degrees
- Advanced new technology blade sections

Product benefits:

- Close to 50% reduction in ship hull vibrations due to propeller induced hull pressures
- About 50% reduction in ship machinery vibration levels due to propeller induced unsteady shaft forces
- Improved propeller efficiency

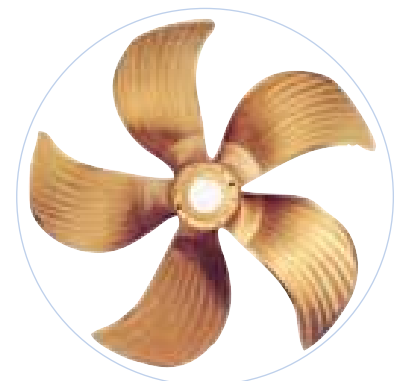

New Generation Workwheels® deliver optimum cavitation and vibration performance with improved structural integrity.

Kamewa™ adjustable bolted propellers

The adjustable bolted propeller allows the most efficient blade matching for optimum efficiency while simplifying the installation process. The Kamewa ABP is based on a hollow hub with blades bolted to it from the inside. A unique feature is the method of bolting the blades to the hub using simple hand tools.

In comparison to conventional monobloc fixed pitch propellers the ABP has higher quality blade machining and reduced overall weight, which give easier shipment, handling and mounting. In service, the slotted holes on the hub allow the blade pitch angle to be conveniently adjusted to compensate for long-term variations in hull resistance. Individual blades can be replaced without drydocking, and only spare blades have to be stocked rather than a complete monobloc propeller.

Key features:

- Spare propeller not needed, thus short pay-off compared to FPP
- Slotted holes on the hub allow stepless blade pitch angle adjustment
- Stainless steel or NiAl-bronze blades
- Simpler, less costly installation at the shipyard. Match marking not needed
- Smaller, lighter components mean lower costs for shipment, storage and handling
- Individual blades can be replaced if damaged
- Easy underwater installation and replacement of blades
- Hollow hub reduces total weight and extends bearing life
- Higher accuracy than a monobloc propeller since individual parts are machined more efficiently
- No limitation in size or weight



When in service, the slotted holes on the hub permit simple pitch angle adjustment.

Typical applications:

- Suitable for larger vessels such as:
- tankers
 - cargo/container vessels
 - various types of naval vessels



The ABP offers fast and simple installation compared to a monobloc unit.

Ulstein Aquamaster™ azimuthing thrusters

Rolls-Royce is one of the world's leading suppliers of azimuth thrusters. The basic idea behind an azimuth thruster is that the propeller can be rotated 360 degrees around the vertical axis, providing omni-directional thrust. The Ulstein Aquamaster azimuth thrusters by Rolls-Royce therefore offer superior manoeuvrability. The simple and robust construction provides high operational reliability along with easy maintenance, which give best possible total economy.

The flexibility in design makes the azimuth thrusters ideal to a wide range of vessels. The low noise and vibration levels further enhance the area of use. The Ulstein Aquamaster thrusters can be delivered for diesel or electric drive. The units are available as open or ducted with fixed or controllable pitch, or with contra-rotating propellers. The azimuthing thrusters are delivered with remote control systems.

Key features:

Mounting options

- Bottom well cover type. All components are mounted on the bottom well cover. The unit is lowered inside the hull and bolted in place
- Weld-in type

Hydraulic pump options

- V-belt-drive from drive shaft
- Driven from PTO
- Driven by separate electric motor

Steering gear drive options are:

- Hydraulic
- Electric

Intermediate shaft arrangement

- Standard shaft arrangement for direct diesel drive is complete assembly with two cardan shafts, support bearings, solid shafts, water-tight bulkhead sealing etc.
- Flexible coupling of prime mover (diesel-engine or electric motor) is optional item.

Typical applications:

Suitable for:

- tugs
- offshore supply/service vessels
- cargo vessels

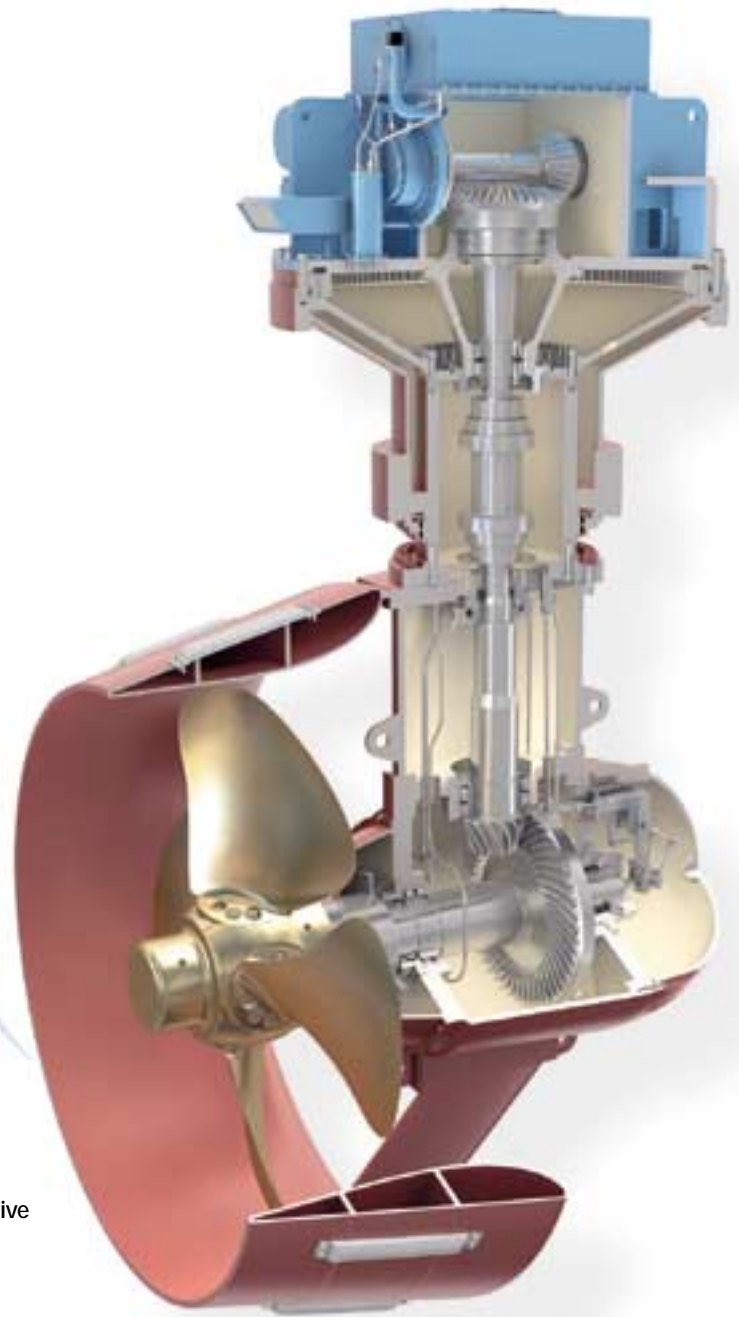

Typical technical data	Ducted FP prop.	Ducted CP prop.	Open prop.
Propeller diameter (mm)	1 050-3 000	1 600-3 000	1 250-3 500
L, nominal stem length (mm)	1 500-4 100	2 400-4 100	1 500-4 100
Weight, dry (kg)*	1 850-40 000	11 200-42 500	1 500-34 500
Nominal input speed (rpm)	750-1 800	750-1 800	750-1 800
Nominal input power (kW)	280-3 000	280-3 000	280-3 000
Bollard pull range (metric tons per two units)	9.5-92	9.5-92	-

For larger units, see table page 15.
Max. dry weight of weld-in installation. All data subject to change without prior notice.

Ulstein Aquamaster™ azimuthing contra-rotating propellers

Ulstein Aquamaster contra-rotating propeller, type Contaz, is the world's first thruster system designed for and built especially for merchant vessels. It combines the benefits of contra-rotating propellers with steerable thrusters. The latest bearing, gear and shaft technology are the keys to the Contaz – refined and developed through decades.

The Contaz also represents a new way of designing and building ships, and to arrange its power and auxiliary systems for maximum economy, utilisation and comfort. Every unit is specifically designed and built for the particular ship it is going to serve. The overall benefits are better outline arrangement, better propulsion efficiency, better fuel economy, better coursekeeping stability and reduced vibration and noise.

Typical applications:

- Suitable for:
- passenger/car ferries
 - offshore supply vessels

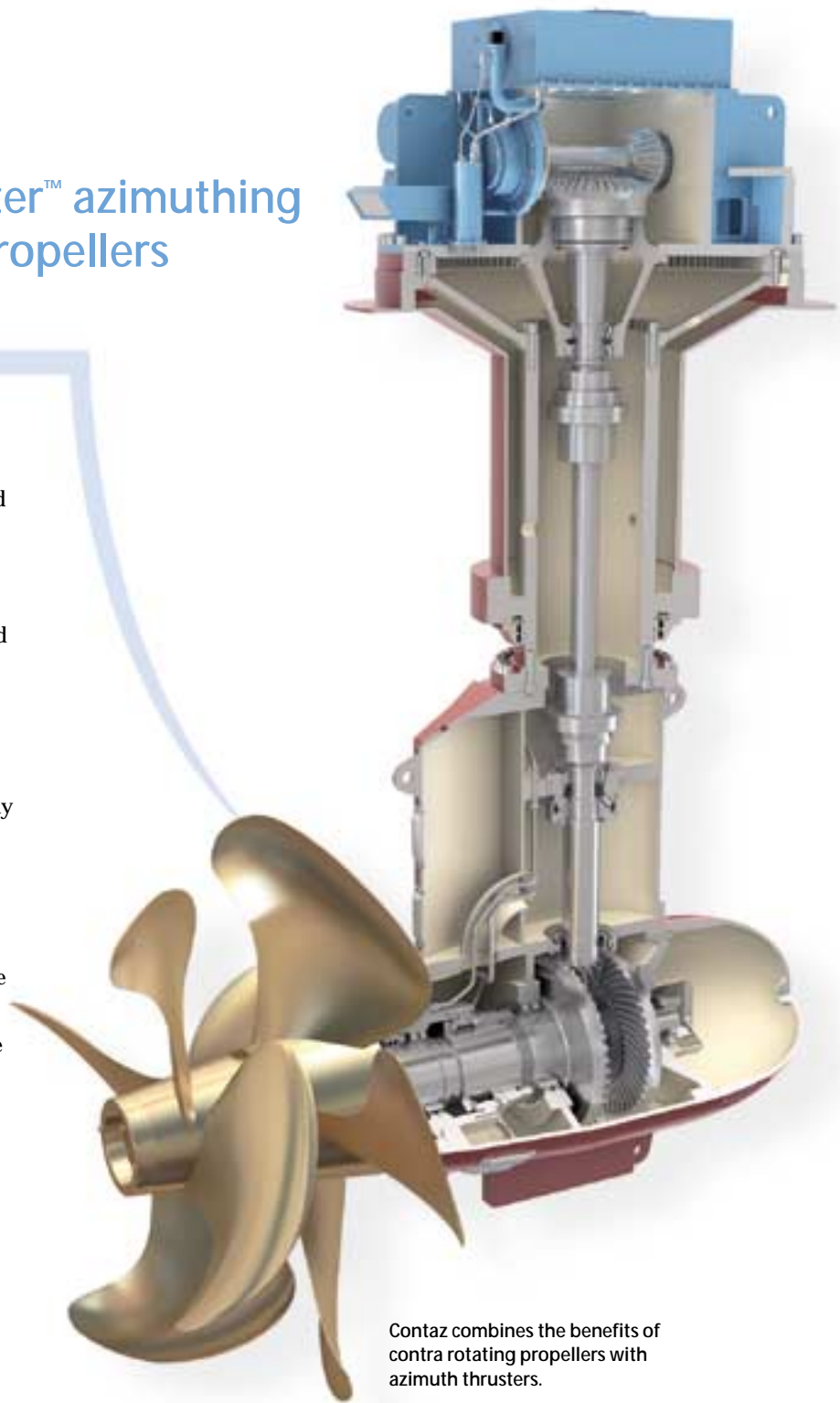

Contaz combines the benefits of contra rotating propellers with azimuth thrusters.

Technical data	Contaz 10	Contaz 15	Contaz 25	Contaz 35	Contaz 50	Contaz 65
Maximum propeller diameter (mm)	2 900	3 200	3 700	4 200	4 500	5 000
Stem length H (mm) Min.	4 100	4 250	5 000	5 600	6 000	6 650
Max.	8 350	8 500	9 500	11 000	12 000	13 000
Weight, dry (kg)*	30	32	50	73	87	120
Nominal input speed (rpm)	750-1 200	750-1 200	750-1 200	750-1 200	600-900	600-900
Power max. kW	1 800	2 200	3 000	3 700	4 500	5 200

Dry weight at shortest stem length (kg). All data subject to change without prior notice.

Ulstein Aquamaster™ azimuthing pulling propeller

Ulstein Aquamaster azimuthing pulling propeller, type Azipull, is a low drag, high efficient pulling thruster. It combines the advantage of the pulling propeller with the flexibility of using almost any type of drive to suit the customer's specific requirement. The Azipull is designed for continuous service speed up to 24 knots, while maintaining excellent manoeuvrability. High hydrodynamic efficiency, fuel efficiency, course stability, low noise and vibration levels are other key characteristics of the Azipull.

Internally, it has a purely mechanical drive system based on well-proven technology using bevel gears at the top and bottom of the leg. Power is fed to the unit through a horizontal input shaft within the hull, and the unit incorporates its own steering motors for azimuthing.

The Azipull combines the advantages of an azimuthing thruster offering high manoeuvrability, and low drag, high efficient propulsor enabling high speeds. The flexibility of the unit is also enhanced by the fact that it is available in both CP and FP versions. The Azipull is delivered with remote control systems.

Typical applications:

- Suitable for:
- offshore supply/service vessels
 - offshore stand-by vessels
 - coastal ferries
 - cargo vessels
 - naval vessels

The streamlined leg and skeg recover swirl energy from the slipstream, raising the overall propulsive efficiency. The leg has a wide chord to optimise rudder effect and improve the vessel's course stability.

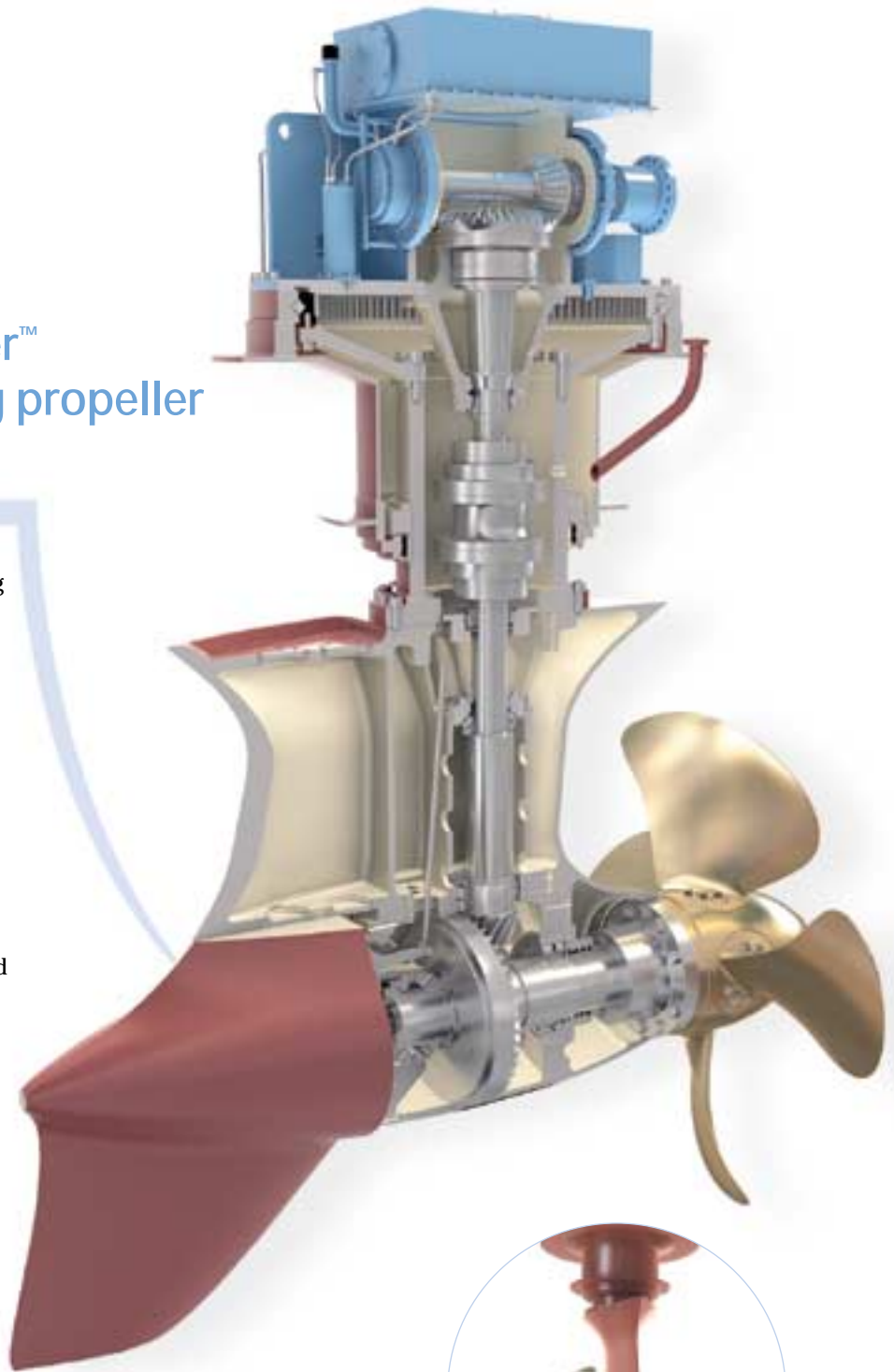

Technical data	AZP085 Catamaran	AZP085 Standard	AZP120 Standard
Propeller diameter (mm)	2 100	2 100	3 200
Power (max cont.rating)	1 500	1 500	3 000
Nominal input speed (RPM)	1 800-2 000	750-1 800	750-1 200
Dry weight (kg)	14 tonnes	16 tonnes	43 tonnes

All data subject to change without prior notice.

Ulstein Aquamaster™ azimuthing swing-up thrusters

This thruster swings up into a housing in the hull when not in use. It can quickly be swung down about a horizontal axis into the operating position. In operation, it functions as an azimuth thruster and is designed to develop maximum bollard pull in the manoeuvring condition, or to provide positioning power for station keeping. The thruster has the added safety benefit of functioning as a «get you home» drive. A high thrust is developed in relation to input power, and this thrust can be vectored in any desired direction.

In the stowed position the thruster does not protrude below the vessel's keel/baseline, an important consideration for shallow water operations. Additional azimuth thrusters are often located at the lowest possible position in the hull due to space envelope restrictions, especially for equipment mounted at the bow, and thrusters need to be retracted into the hull when not in use.

Key features:

- Can be delivered as containerised unit
- Available in CP and FP propeller
- Electric or diesel drive
- Remote control system

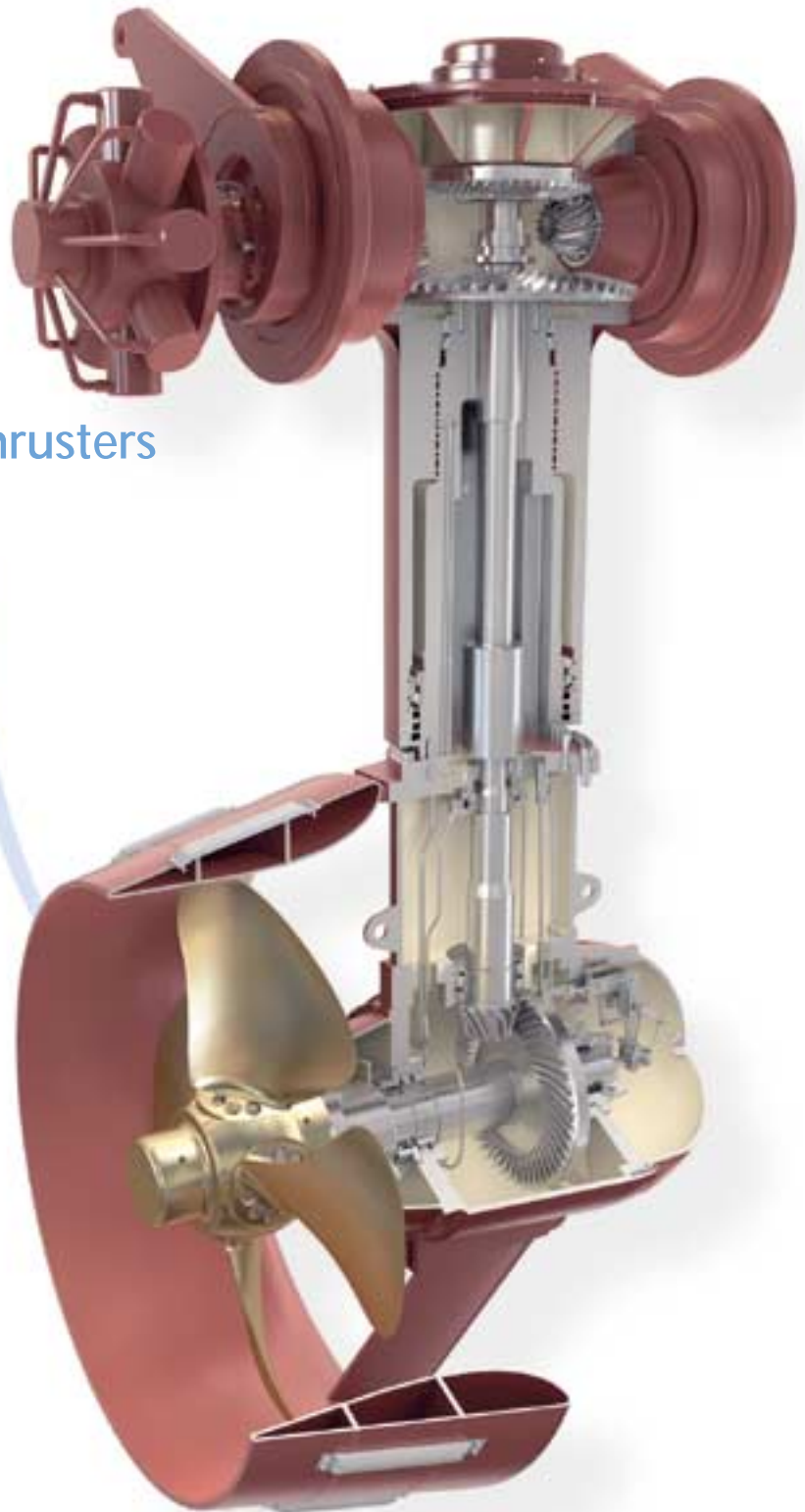

This thruster unit is used in both swing-up and combi version.

Typical applications:

Suitable for:

- tankers
- cargo vessels
- cruise ships/ferries
- arctic vessels
- drilling rigs
- various types of naval support vessels



The swing-up principle.

Ulstein Aquamaster™ combined azimuth/side thrusters

Ulstein Aquamaster combi thruster is stored in the ship's hull by rotating the complete unit 90 degrees around the horizontal axis. In the retracted position, the thruster can be operated as a side force thruster. The upper part of the thruster is hinged, enabling the thruster to be lowered through an arc into its azimuthing position or retracted into a recess where it lies horizontally in the hull.

The Ulstein Aquamaster thruster is designed as a nozzle propeller in lowered as well as retracted position. This means low noise and higher thrust compared with a traditional tunnel thruster.

The combi thruster version is comprised of an equivalent standard "Swing-up" unit installed in a specially designed hull module. When in swing-up position (retracted) the steering gear may be rotated so that the

propeller unit is used as a transverse thruster.

Speed of response in terms of changing thrust direction is similar to conventional thrusters. The steering unit can be rotated through 180° in some 10 seconds. The combi thruster is delivered with remote control system.

Typical applications:

Suitable for:

- offshore supply/service vessels
- offshore production vessels
- ROV/survey support ships
- tugs
- fishery research vessels
- various naval support vessels

Key features:

- Available in CP and FP propeller
- Electric or diesel drive

Two operation modes:

- 360° rotatable as azimuth
- Side thruster when retracted

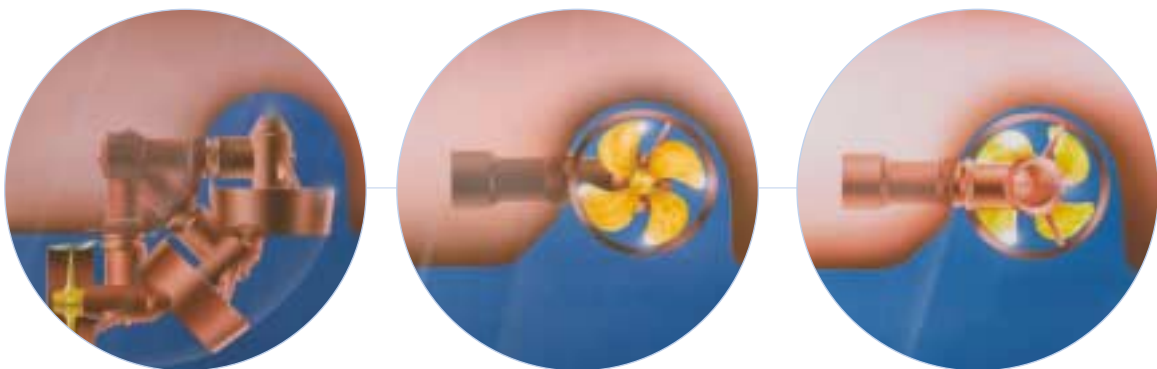

The thruster is 360° rotatable and swings up into a shallow recess in the hull bottom.

Technical data for Kamewa Ulstein combined azimuth/side thrusters and swing-up thrusters

Technical data	SU/SC 105	SU/SC 155	SU/SC 175	SU/SC 205	SU/SC 255	SU/SC 305
Propeller diameter (mm)	1 600	1 800	2 150	2 400	2 600	3 000
Max. power (kW)	500	900	1 300	1 500	2 200	3 000
Nominal input speed (rpm)	1 800	1 800	1 800	1 800	720-750	720-750
Weight thruster w/steering gear	8 500	9 500	15 000	17 000	35 000	40 000
Weight hull module	9 000	10 000	17 000	17 000	45 000	50 000

All data subject to change without prior notice.

Ulstein Aquamaster™ azimuthing underwater mountable thrusters

Ulstein Aquamaster underwater mountable thruster is designed for easy underwater mounting and dismantling without drydocking the application. This is of utmost importance to large vessels and semi-sub oil drilling rigs.

The procedure is performed easily and safely, thanks to a specially developed lifting arrangement and a unique sealing- and locking device incorporated in the thruster column. Available with CP and FP propeller.

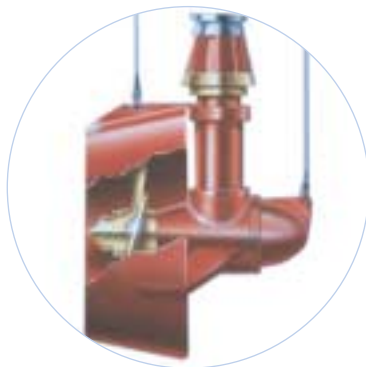

Underwater mounting and demounting, type UUP.

Underwater mounting and demounting, type UUC.

Technical data	305		355		405	455	505
Propeller diameter (mm)	2 800	3 000	3 200	3 500	3 800	4 100	4 500
Nominal power (kW)	2 700	3 000	3 300	3 800	4 600	5 500	6 500
Nominal input speed (rpm)	750	1 200	750	1 200	750-1200	750-1200	750-1200

All data subject to change without prior notice.

The basic unit is also available for dry-dock installations

Typical applications:

Suitable for:

- semi-sub drilling rigs/ ships
- production vessels
- other large vessels

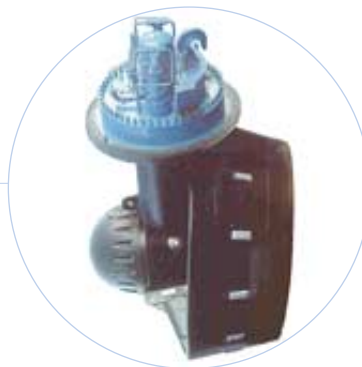

USE is designed for installation in dry conditions. This type can be mounted directly to the hull or in a container. The container can be either of retrievable or retractable type.

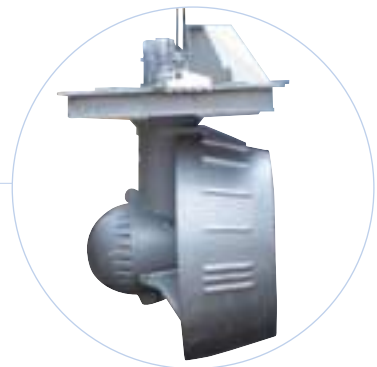

USL is a compact design with bottom well and foundation for vertical drive motor. USL installation method means wet mounting from the top through a wet casing.

Ulstein Aquamaster™ azimuthing retractable thrusters

Ulstein Aquamaster retractable thruster has the same main components as our other azimuthing thrusters. The retractable thrusters provide fast hydraulic lifting and lowering of the unit.

The mounting is a "bolt in" top mounted type. A casing plate is welded into the hull structure, the thruster unit is lowered into the well, aligned, and the lower support is welded into the well sides.

A containerised version is also available. This concept ensures simple installation. The yard can carry out the installation in a single operation, as the thruster is pre-installed in the container unit. The container unit can be removed for repair without dry-docking and with a minimum of preparatory work.

The thruster is available with either CP or FP propeller.

Steering and lubrication hydraulic pump drive

The pump drive options are:

- Direct drive from drive shaft in case of diesel prime mover
- Electric motor in case of electric prime mover

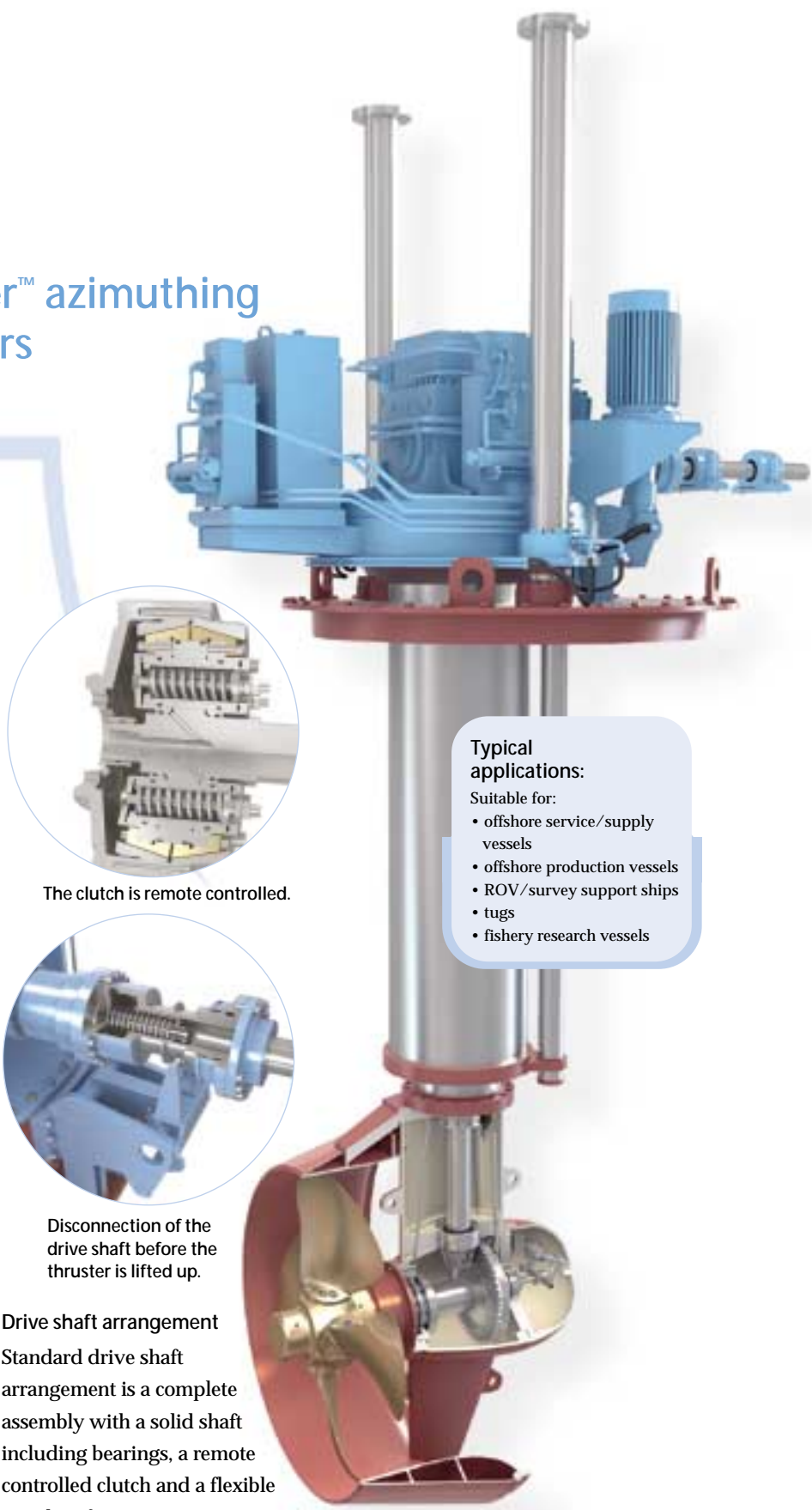

Typical applications:
 Suitable for:

- offshore service/supply vessels
- offshore production vessels
- ROV/survey support ships
- tugs
- fishery research vessels

Drive shaft arrangement
 Standard drive shaft arrangement is a complete assembly with a solid shaft including bearings, a remote controlled clutch and a flexible coupling for prime mover.

Technical data	UL/ULE 105	UL/ULE 105	UL/ULE 155	UL/ULE 155	UL/ULE 175	UL/ULE 205	UL/ULE 255	UL/ULE 305
Propeller diameter (mm)	1 050	1 300	1 600	1 800	2 150	2 300	2 800	3 000
	FP	FP	FP	FP/CP	FP/CP	FP/CP	FP/CP	FP/CP
Max. aux. DP power (kW)	280	440	850	1 090	1 300	1 500	2 200	3 000
Nominal input speed (rpm)	750-1 800	750-1 800	750-1 800	750-1 800	750-1 800	750-1 800	750-1 800	750-1 200
Dry weight, (kg)	3 600	6 000	8 500	18 000	20 000	27 500	38 000	74 000

All data subject to change without prior notice.

Kamewa Ulstein™ tunnel thrusters

Kamewa Ulstein tunnel thrusters are fitted to a wide range of vessels operating in all corners of the world. The tunnel thruster is designed for giving max. side force to the ship in manoeuvring condition. The system normally consists of the thruster unit with tunnel, hydraulic equipment, remote control and electrical drive-motor with starter. Thrusters are available in both CP and FP versions.

Super Silent type

The Super Silent thruster is designed with double walls in the full tunnel length, and flexible mounted inner tunnel. This concept provides noise reduction up to 15 dB compared to standard designs. A reduction up to 25 dB can be reached in combination with floating floors and other measures by the shipbuilder.

Key features:

- Reduced tip speed (Super Silent only)
- Skew blades

- 15 – 25 dB noise reduction (Super Silent only)
- Drive shaft seal can be changed without removing electric motor
- Heavy duty propeller in DP condition
- Shaft seal pressure control with drain connection in DP condition
- Mechanical locked bearings in DP condition
- For ICE version, blade design of caplan type
- Available in CP and FP type

Technical data , type TT-CP/FP

D mm	Maximum Power kW					
	El motor			Diesel		
	Version AUX	Version ICE/DPN/DPD	Version DPN/DPD	Version AUX	Version ICE/DPN/DPD	Version DPN/DPD
1100	330-390	300-350	300-350	290-340	260-310	260-310
1300	495-595	445-535	445-535	435-520	390-475	260-310
1650	750-865	700-780	700-810	650-760	600-685	650-710
1850	900-1 050	800-950	850-950	800-930	700-840	700-840
2000	1 295-1 030	1 165-925	1 205-950	1 140-905	1 025-815	700-840
2200	1 240-1 510	1 115-1 365	1 180-1 440	1 090-1 325	980-1 190	1055-845
2400	1 580-1 910	1 420-1 720	1 420-1 710	1 390-1 680	1 250-1 510	1245-1510
2650	2 400-2 150	2 160-1 935	2 205-1 980	2 110-1 892	2 000-1 700	1935-1735
2800	2 650-2 380	2 385-2 140	2 385-2 140	2 330-2 090	2 096-1 880	2095-1880
3000	2 510-3 000	2 260-2 700	2 260-2 700	2 210-2 640	1 990-2 370	1990-2380
3300	3 100-3 700	2 790-3 330	2 790-3 330	2 730-3 250	2 450-2 930	2450-2930

All data subject to change without prior notice.

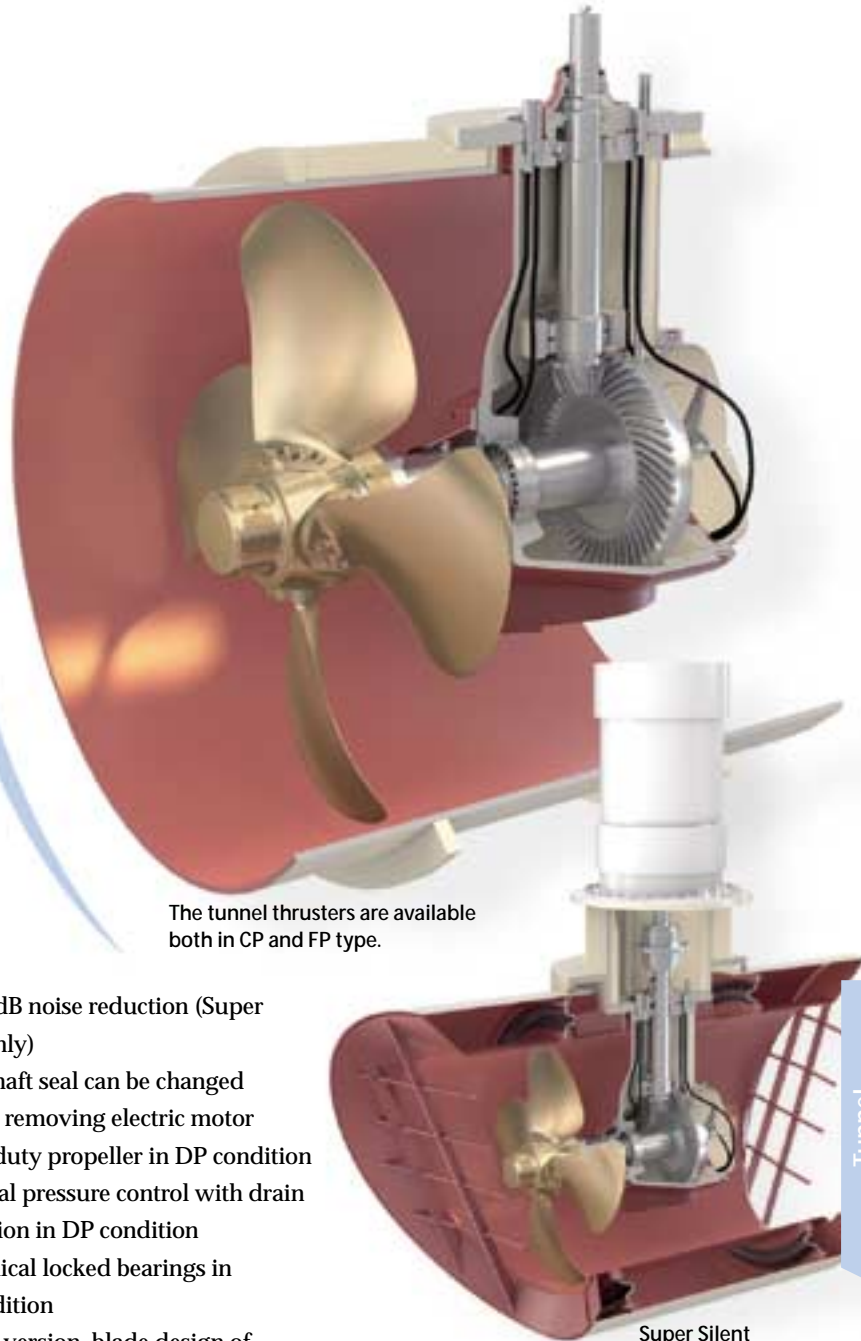

The tunnel thrusters are available both in CP and FP type.

Super Silent thruster with double mounted tunnel.

Typical applications:

Suitable for and installed in all types of vessels.

Technical data , type TT-SS

Thruster type	D	Max. RPM	Prop. RPM	Max. Power
TT1850 SS	1850	1 180	290	800
TT2000 SS	2000	1 180	245	925
TT2200 SS	2200	1 180	276	1 355
TT2200 SS	2200	1 180	243	1 050
TT2400 SS	2400	1 180	257	1 720
TT2400 SS	2400	1 180	228	1 350
TT 2650 SS	2650	880	204	1 935

Mermaid™ – azimuthing podded propulsor

The Mermaid pod propulsion system combines the expertise of Rolls-Royce in propulsion, hydrodynamics and azimuthing thrusters with the experience of Alstom in electric propulsion drives. In addition to the flexibility in machinery and vessel arrangement offered by electric propulsion drives, the Mermaid system gives improved efficiency and excellent manoeuvrability.

The Mermaid outboard part is 360 degrees rotatable for manoeuvring purposes, or +/- 35 degrees hardover/hardover in transit, by the means of a hydraulically operating steering gear. The main component in the underwater unit is the electric motor, in this case of synchronous type with brushless excitation and with a stator shrink fit in the pod housing. The motor is equipped with double windings in order to permit a continuous operation > 50% load, even in case of winding failure. There is also a shaft brake, locking device and equipment to slowly turn the shaft in order to assist when undertaking maintenance work.

The propeller is of fixed pitch Kamewa HS-type characterised by low noise and vibration, and can be either delivered with separately bolted blades or cast as a complete monobloc. A feature with separately bolted blades is that these can be changed more easily in case of damage, one by one.

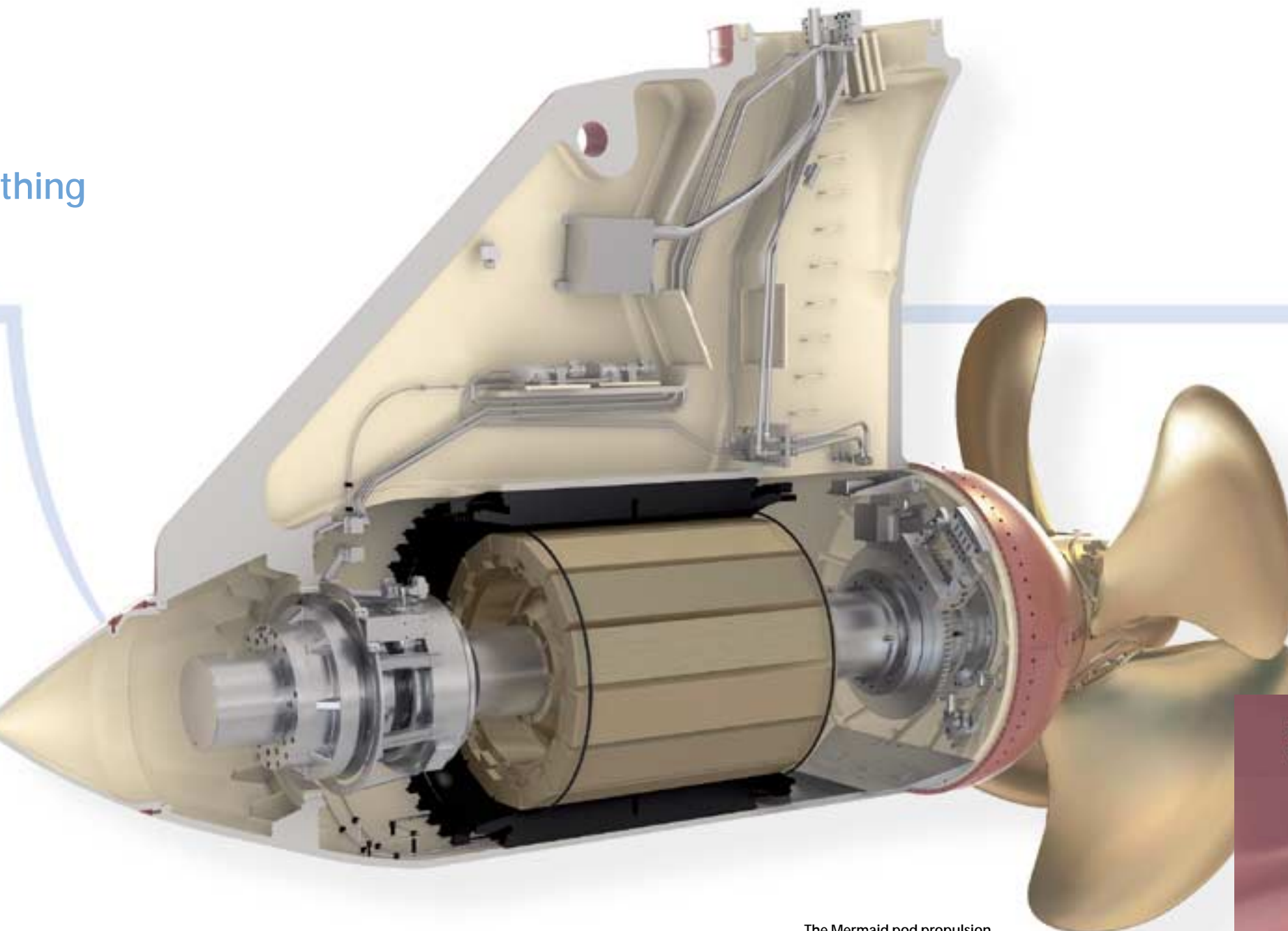

The Mermaid pod propulsion system is available from 5-25 MW.

All seals against seawater are of environmentally friendly type, i.e. a seal failure will not create any oil spill into the water.

Owner/Operator benefits:

- Increased cargo capacity or reduced vessel size
- Increased propulsion system efficiency
- Increased propulsion system redundancy and power availability
- Reduced total installed power generation
- Reduced total fuel consumption & exhaust emissions

- Reduced maintenance and repair
- Reduced noise & vibration levels
- Reduced vessel turning circle

Shipyard & Construction benefits:

- Flexible machinery arrangement
- Modularised design
- Simpler vessel machinery installation
- Simpler hull form and structure
- Reduced installation time and cost
- Fewer components
- Reduced shipyard/sub-supplier co-ordination work

Typical applications:

- Suitable for:
- offshore rigs
 - tankers
 - cruise ships
 - Ro-Ro ferries
 - naval ships

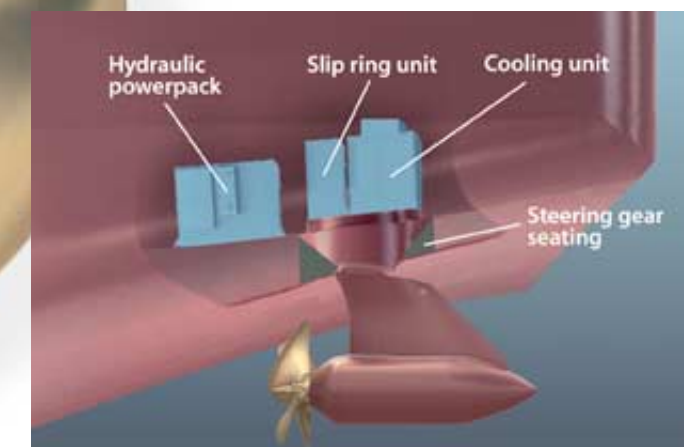

Mermaid is a space-saving and cost-efficient propulsion system.

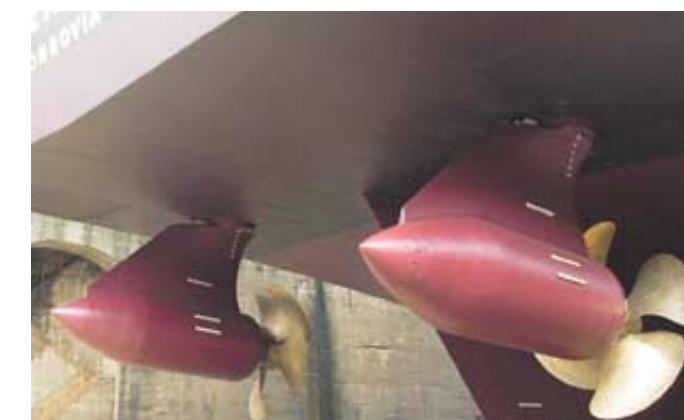

Mermaid can be mounted and serviced without dry-docking.

Kamewa™ waterjets

Forward propulsion

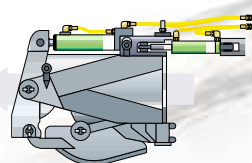

Zero speed

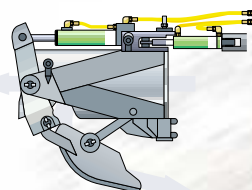

Reversing

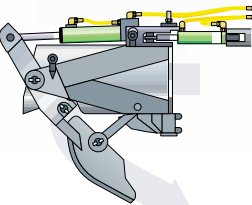

Steering port

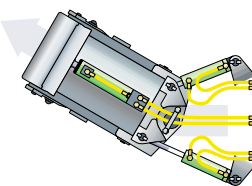

Steering starboard

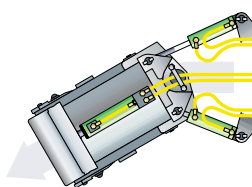

The ability to accelerate, reverse, stop and steer is excellent compared to propeller propulsion.

Superior performance and manoeuvrability

The water jet has many advantages over a propeller. Kamewa waterjets have a very high pump efficiency. This provides higher speeds with the same power, or, substantially lower fuel consumption at a constant speed and lower power.

At constant rpm, Kamewa waterjets absorb approximately the same power regardless of the ship's speed. The engine cannot be overloaded, which means fewer breakdowns and an increased life cycle.

Waterjets produce less vibration and noise than propellers. At speeds over 20 knots, the vibration and noise can be reduced by more than 50 percent. In addition, with two or more waterjets, manoeuvrability is excellent, making quick dockings with perfect precision standard every time.



The impeller's rotation is never reversed, so no reversible gearbox is needed for this action.

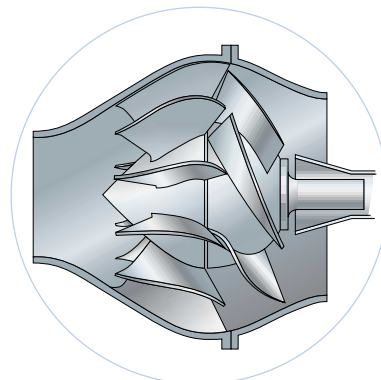

The impeller's task is to pressurise the water. The reaction force that is created when the water leaves the pump is utilised to propel the ship.

Kamewa™ mixed-flow waterjets, S-and A-series

Waterjets S-series

The Kamewa S-series of waterjets is developed for the largest and most demanding applications. The waterjets are equipped with a mixed-flow pump for maximum efficiency. To facilitate the hydrodynamic performance of the pump the built-in bearings keep the impeller in correct position and provide control of the important tip-clearance. The outboard bearing position also simplifies the overall load distribution in the aftship and leads to efficient use of the inlet duct as load carrying structure.

The S-series have five impeller blade angles, eight pump outlet nozzle and at least 10 variations of inlet duct designs are utilised to optimise the unit for each application. Minimal and simple cable installation is achieved through computerised databus-based system for steering and reversing control, which can be used for both manual and joystick manoeuvring. The system provides redundancy and real-time

control with a very high level of security. The Kamewa S-series are manufactured entirely in stainless steel for maximum wear and corrosion resistance.

Waterjets A-series

Kamewa A-series is the first and only aluminium waterjet series in the world with mixed-flow pump technology.

Typical applications:

S-series

Suitable for larger high speed craft such as:

- passenger/car ferries
- larger naval vessels
- excellent for both monohulls and multihulls

A-series

Suitable for:

- smaller passenger ferries
- rescue boats
- smaller high speed naval craft

Due to the utilisation of the mixed-flow pumps, hydrodynamically optimised design and exacting production techniques, the A-series has 5-10% higher efficiency than competing aluminium axial flow waterjets.

The impeller shaft and steering-/reversing rods are made of stainless steel. All other components are made of light aluminium. The impeller housing is lined with polyurethane or stainless steel depending on the application's operational profile. A water-lubricated cutless bearing is used for ease of service and maintenance.

All S- and A-series waterjets can be supplied as booster unit with our steering and reversing gear.

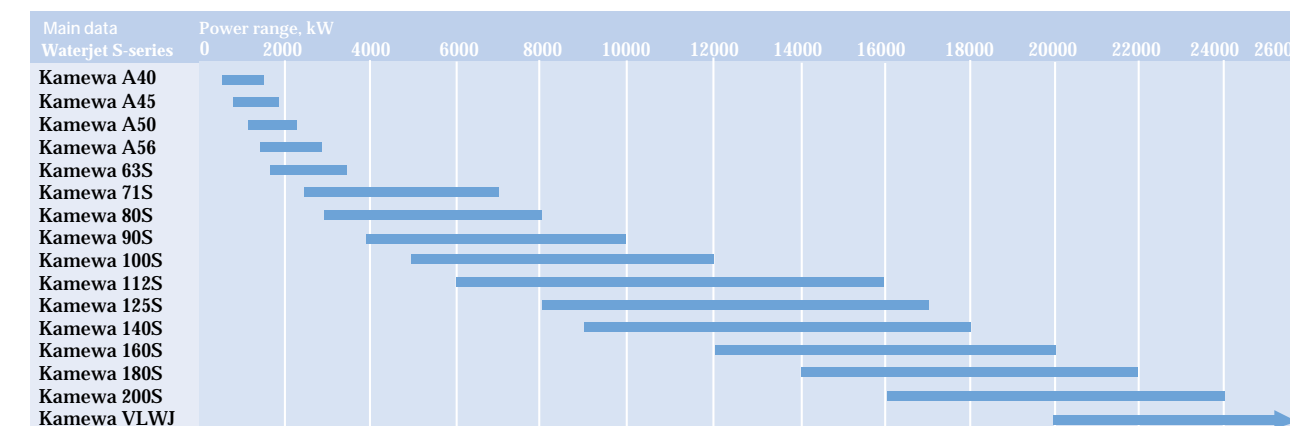

On customer's request size 40-56 waterjets can also be delivered in stainless steel.

Kamewa™ axial flow waterjets, FF-series

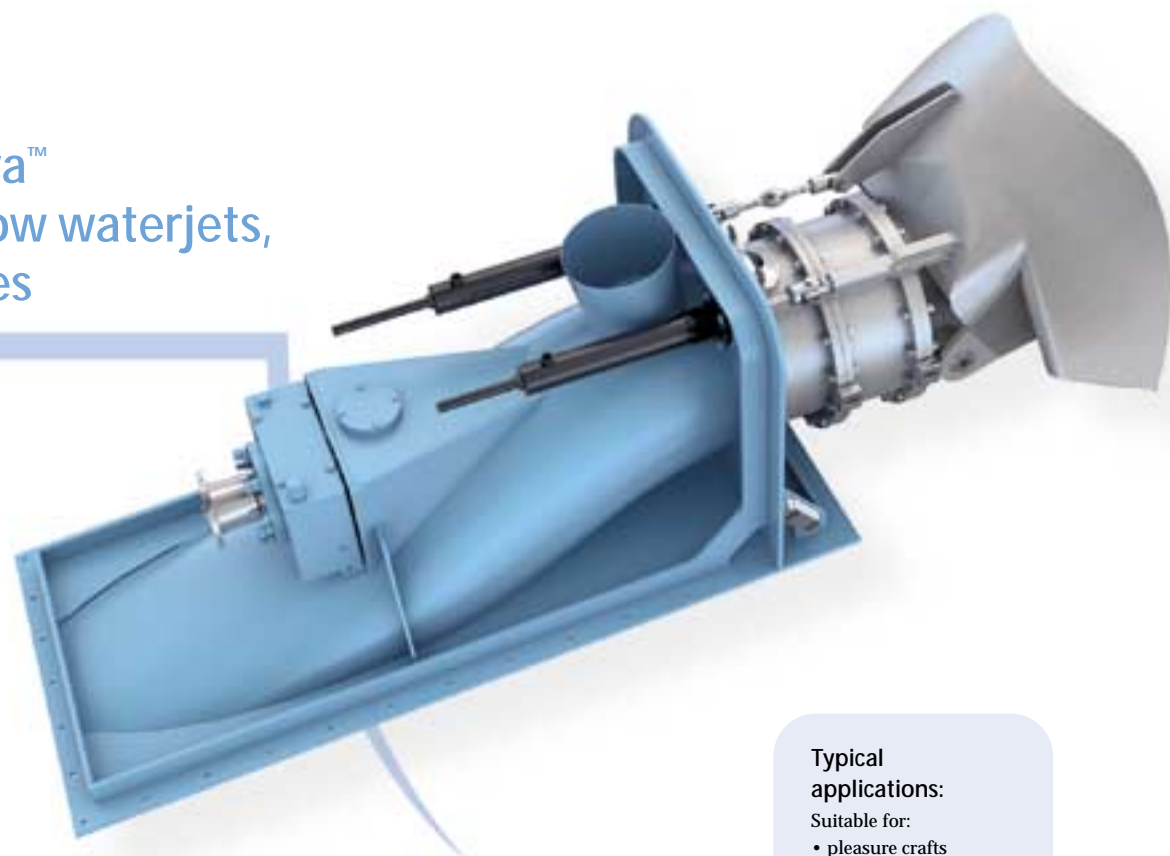

Waterjets FF-series

The FF-series water jet units are manufactured from strong, corrosion resistant materials. The impeller shaft and steering/reversing rods are made of stainless steel, remaining components are made of light aluminium. The interior surface of the impeller housing is lined with a special rubber-like material to minimise wear and noise.

The pump is a single-stage axial flow design, providing a high volume flow with good pulling thrust at lower speeds. Usually, the FF-series jets do not require reduction gears.

All FF-series waterjets can be supplied as booster unit without steering and reversing gear.

The FF-series waterjets have in several comparison tests proved to have 5% higher thrust force than the competing waterjets.

The FF-series can be installed on both displacement and planing craft as single, twin, triple or quadruple systems.

Typical applications:

- Suitable for:
- pleasure crafts
 - workboats
 - smaller harbour vessels
 - small naval vessels

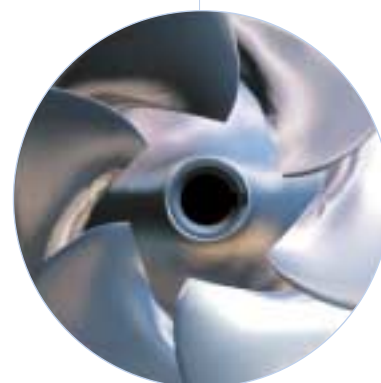

Axial flow impeller is usually designed to match the rpm of the engine and therefore reduction gear is not always required.

Higher performance at a lower cost

Upgrading replacement components can make dividends in vessel performance and fuel savings.



Once a product is in service, it is expected to last 25 years or more. During that time, there will be tremendous changes in the technology available.

To continuously improve your vessel's performance, we provide a variety of upgrading solutions. The advances in propeller design can help older vessels. I.e. replacing old blades with new ones on an existing CP hub can pay dividends in saving fuel. Modules are often developed so that

when an old unit is overhauled, a new module is substituted for worn components of the original design. This upgrades the performance of the product as well as restoring it to health.

With Rolls-Royce as your service partner, our experienced engineers upgrade old applications or purpose fit new equipment to your vessel. This means that you can meet changing markets without having to do expensive rebuilds in many cases.



UPGRADING

Our upgrading solutions can give your ship a new lease of life with improved fuel economy, reduced noise and vibrations and increased speed and manoeuvrability.

Main data	Power range, kW												
Waterjet FF-series	0	250	500	750	1000	1250	1500	1750	2000	2250	2500	2750	3000
Kamewa FF-240													
Kamewa FF-270													
Kamewa FF-310													
Kamewa FF-375													
Kamewa FF-410													
Kamewa FF-450													
Kamewa FF-550													

Global Service and Support

The Rolls-Royce Service and Support concept has been developed to secure complete life-cycle support for your ship and its equipment.

We enable you to choose the kind of service level you need in the most cost-efficient way. Choose between day-to-day servicing, service agreements or a comprehensive service solution.

THE PARTNER SOLUTION

A comprehensive service agreement Lifelong support means less downtime, low life-cycle costs and proven high second-hand value. The Partner Solution provides you with these important advantages. This service solution allows you to optimise your daily routines, and ensures that our servicing puts your investment in the best hands. This also allows you to structure your own after-sales service to increase reliability and economy for your applications' operating conditions.

SERVICE AGREEMENTS

We save you time and money Time is crucial, so swift and correct response to enquiries or problems is of mutual benefit. Our aim is to increase your profitability by implementing long-term and cost-effective service agreements. These include delivering original replacement units, regular on-site inspections and personnel training.

BASIC SUPPORT

We get you back in business Our Service and Support is based on reliability, determination and the expertise to carry out services and deliveries at short notice. The Basic Support Agreement gives you access to our skilled field workers and genuine spare parts supplies, wherever and whenever you need them.

The agreement also includes access to our in-house repair and maintenance centres all over the world.

WORLDWIDE AVAILABILITY

We are always present A Rolls-Royce service centre is never far away, no matter where you are. With a comprehensive network of service centres around the world, we are a global company and yet still local. We offer 24-hour availability worldwide, backed by a first class logistics system, which secures you rapid response to inquiries within the shortest possible time.



Rolls-Royce gives a guarantee on all repairs carried out. The length depends on the type of work and the actual application.



NORTHERN EUROPE**DENMARK**

ROLLS-ROYCE
Aalborg (Service)
Tel: +45 99 30 36 00
Fax: +45 99 30 36 01

FINLAND

ROLLS-ROYCE
Helsinki
Tel: +358 9 686 6330
Fax: +358 9 686 63339
Kokkola (Water jets)
Tel: +358 6 832 4500
Fax: +358 6 832 4511
Rauma (Propulsion/
Deck Machinery)
Tel: +358 2 837 91
Fax: +358 2 837 94804

FRANCE

ROLLS-ROYCE
Rungis
Tel: +33 1 468 62811
Fax: +33 1 468 79398
Paris (Naval Marine)
Tel: +33 147 221 440
Fax: +33 147 457 738

GERMANY

ROLLS-ROYCE
Hamburg, Jessenstr.
Tel: +49 40 381 277
Fax: +49 40 389 2177
Hamburg, Kamerunweg
(Service)
Tel: +49 40 780 91 90
Fax: +49 40 780 91 919
Norderstedt
Tel: +49 40 52 87 36 0
Fax: +49 40 52 31 58 0

THE NETHERLANDS

ROLLS-ROYCE
Rotterdam, Pernis (Service)
Tel: +31 10 40 90 920
Fax: +31 10 40 90 921

NORWAY

ROLLS-ROYCE
Bergen (Foundry)
Tel: +47 55 53 65 00
Fax: +47 55 53 65 05
Bergen (Engines)
Tel: +47 55 53 60 00
Fax: +47 55 19 04 05
Bergen (Steering gear)
Tel: +47 56 57 16 00
Fax: +47 56 30 82 41
Brattvåg (Deck Machinery)
Tel: +47 70 20 85 00
Fax: +47 70 20 86 00
Hareid (Rudders)
Tel: +47 70 01 40 00
Fax: +47 70 01 40 21
Longva (Automation)
Tel: +47 70 20 82 00
Fax: +47 70 20 83 51
Tennfjord (Steering Gear)
Tel: +47 70 20 88 00
Fax: +47 70 20 89 00
Ulsteinvik (Head Office)
Tel: +47 70 01 40 00
Fax: +47 70 01 40 05
Ulsteinvik (Ship Design)
Tel: +47 70 01 40 00
Fax: +47 70 01 40 13
Ulsteinvik (Propulsion)
Tel: +47 70 01 40 00
Fax: +47 70 01 40 14
Volda (Propulsion)
Tel: +47 70 07 39 00
Fax: +47 70 07 39 50
Oslo (Repr. office)
Tel: +47 23 31 04 80
Fax: +47 23 31 04 99
Ålesund (Ship Design)
Tel: +47 70 10 37 00
Fax: +47 70 10 37 01

POLAND

ROLLS-ROYCE
Gniew (Deck Machinery)
Tel: +48 58 535 22 71
Fax: +48 58 535 22 18

Gdynia
Tel: +48 58 782 06 55
Fax: +48 58 782 06 56

SWEDEN

ROLLS-ROYCE
Kristinehamn (Propulsion)
Tel: +46 550 84000
Fax: +46 550 18190

UNITED KINGDOM

ROLLS-ROYCE
Newcastle (Bearings)
Tel: +44 191 273 0291
Fax: +44 191 272 2787

Dartford
Tel: +44 1322 394 300
Fax: +44 1322 394 301

Dunfermline (Motion
Control/RAS)
Tel: +44 1383 82 31 88
Fax: +44 1383 82 40 38

Bristol (Naval Marine)
Tel: +44 117 974 8500
Fax: +44 117 979 2607

Bristol (Marine Systems)
Tel: +44 117 979 5456
Fax: +44 117 979 5632

Derby (Naval Marine-
Submarines)
Tel: +44 1332 661 461
Fax: +44 1332 622 935

Manchester (Engines-Crossley
Pielstick)
Tel: +44 161 223 1353
Fax: +44 161 223 7286

Worcestershire (Allen Gears)
Tel: +44 1386 552 211
Fax: +44 1386 554 491

SOUTHERN EUROPE**CROATIA**

ROLLS-ROYCE
Rijeka
Tel: +38 5515 00100
Fax: +38 5515 00101

ITALY

ROLLS-ROYCE
Genova
Tel: +39 010 572 191
Fax: +39 010 572 1950

SPAIN

ROLLS-ROYCE
Tarragona
Tel: +34 977 296 444
Fax: +34 977 296 450

Madrid
Tel: +34 917 356 736
Fax: +34 917 356 737

ASIA PACIFIC**AUSTRALIA**

ROLLS-ROYCE
Melbourne
Tel: +61 3 9873 0988
Fax: +61 3 9873 0866

Perth
Tel: +61 8 9336 7910
Fax: +61 8 9336 7920

North Ryde (Naval Marine)
Tel: +61 2 9325 1222
Fax: +61 2 9325 1394

NEW ZEALAND

ROLLS-ROYCE
Christchurch
Tel: +64 3 337 6420
Fax: +64 3 337 6421

CHINA

ROLLS-ROYCE
Shanghai
Tel: +86 21 6387 8808
Fax: +86 21 5382 5793

Hong Kong
Tel: +852 2526 6937
Fax: +852 2868 5344

Dalian
Tel: +86 411 230 5198
Fax: +86 411 230 8448

INDIA

ROLLS-ROYCE
Mumbai
Tel: +91 22 820 45 41/-823 53 19
Fax: +91 22 820 45 42

SINGAPORE

ROLLS-ROYCE
Singapore
Tel: +65 686 21 901
Fax: +65 686 22 477

UNITED ARAB EMIRATES

ROLLS-ROYCE
Dubai
Tel: +971 4 299 4343
Fax: +971 4 299 4344

NORTH EAST ASIA**JAPAN**

ROLLS-ROYCE
Tokyo
Tel: +81 3 3237 6861
Fax: +81 3 3237 6846

KOREA

ROLLS-ROYCE
Busan (Deck Machinery)
Tel: +82 51 831 4100
Fax: +82 51 831 4101

RUSSIA

ROLLS-ROYCE
Vladivostok
Tel: +7 4232 495 484
Fax: +7 4232 495 484

AMERICAS**BRAZIL**

ROLLS-ROYCE
Rio de Janeiro
Tel: +55 21 3860 8787
Fax: +55 21 3860 4410
Rio de Janeiro (Naval Marine)
Tel: +55 21 2277 0100
Fax: +55 21 2277 0186

CANADA

ROLLS-ROYCE
Halifax
Tel: +1 902 468 2883
Fax: +1 902 468 2759

St. Johns
Tel: +1 709 364 3053
Fax: +1 709 364 3054

Vancouver (Propulsion)
Tel: +1 604 942 1100
Fax: +1 604 942 1125

USA

ROLLS-ROYCE
Fort Lauderdale
Tel: +1 954 745 5400
Fax: +1 954 745 5401

Houston
Tel: +1 713 273 7700
Fax: +1 713 273 7776

New Orleans
Tel: +1 504 464 4561
Fax: +1 504 464 4565

Seattle
Tel: +1 206 782 9190
Fax: +1 206 782 0176

Annapolis (Naval Marine Inc)
Tel: +1 410 224 2130
Fax: +1 410 266 67221

Miami (Syncrolift Inc)
Tel: +1 305 670 8800
Fax: +1 305 670 9911

Pascagoula (Foundry-Naval
Marine)
Tel: +1 228 762 0728
Fax: +1 228 769 7048

Walpole (Naval Marine Inc)
Tel: +1 508 668 9610
Fax: +1 508 668 2497

Washington (Naval Marine Inc)
Tel: +1 703 834 1700
Fax: +1 703 709 6086



Rolls-Royce plc

Commercial Marine

PO Box 160, N-6065 Ulsteinvik, Norway

Tel. +47 70 01 40 00

Fax +47 70 01 40 05

Naval Marine

PO Box 31 Fishponds, Bristol BS16 1XY, England

Tel. +44 117 974 8500

Fax +44 117 979 2607

www.rolls-royce.com